



24 Volt Interface Adapter

INSTALLATION/ APPLICATION MANUAL

208/230V~60Hz,1Ph

115V~60Hz, 1Ph

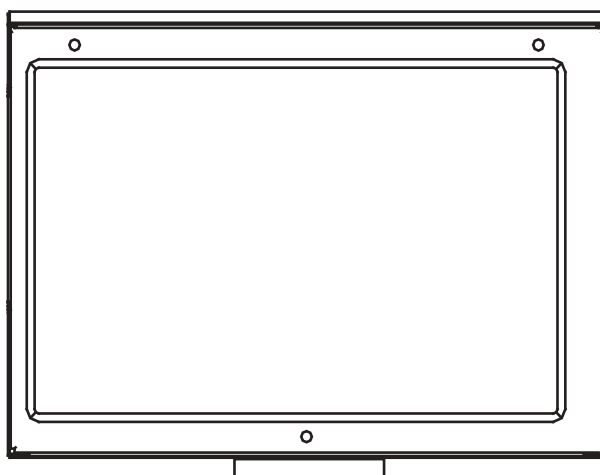

***Makes any Pioneer Quantum Series mini split system
compatible with 24V analog heat pump thermostats!***

IMPORTANT NOTE:

Read this manual carefully before installing or operating your new 24 Volt Interface Adapter. Make sure to save this manual for future reference.

Table of Contents

Preparation Before Installation.....1

Installation Method..... 2

System Configuration..... 2

Application..... 3

Control Logic.....9

DIP Switch Definitions.....10

Error Codes.....11

Wiring Diagram.....12



Read this manual carefully before installing or operating your new air conditioning unit. Make sure to save this manual for future reference.

⚠ WARNING

- Wires must be properly sized according to the NEC/NFPA 70, CEC and all prevailing codes, ordinances and standards.
- All conductors must be installed with a strain relief eliminating stress on the wire following installation which may result in wire damage and/or overheating with a potential for fire.
- Installation must be performed in accordance with the requirement of NEC and CEC by authorized personnel only.
- All wiring to be rated for the control box amperage rating.
- All wiring installed to meet general industry standards and practices,
- Do not install adapter near flammable liquids or gases.
- Do not operate the unit with wet hands, as this could lead to electrical shock.

⚠ CAUTION

- When connecting with RS 485 communication to the outdoor unit, shielded wire must be used and grounded at one end only.
- When using shielded wire the cable should be grounded at one end to reduce EMI.
- T1 sensor cable shall not exceed 23' (7 m).

Read this manual carefully before installing or operating your new air conditioning unit. Make sure to save this manual for future reference.

Wall-Mounted 24V INTERFACE KIT Installation

Wear appropriate personal protection equipment (PPE) when installing or servicing.

24V INTERFACE KIT Dimensions

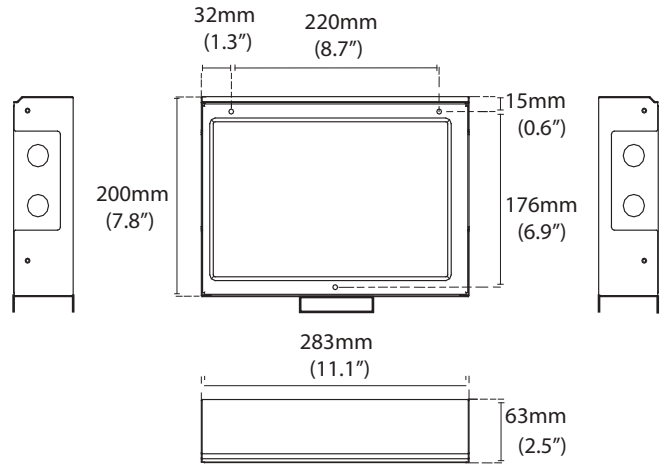
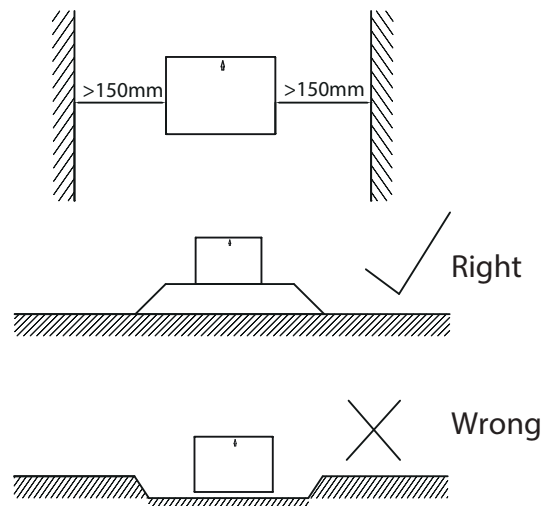

Fig. 1

This interface must be installed indoors in an area free from drips and moisture.



**General installation instructions
Location and clearances**

Preparation Before Installation

1. Ensure you have the following parts

Table 1

No	Name	Quantity	Remarks
1	Control box	1	
2	Screws	3	M4*20 (For mounting on the wall)
3	Anchors	3	For mounting on the wall
4	The connective wires group	2	For connecting the sensor
5	5m connective wires group	1	

2. Prepare the following tools

Table 2

No	Name	Quantity
1	Switch box	1
2	Wiring tube (insulating sleeve and tightening screw)	1

3. Select installation location

DO NOT install the 24V INTERFACE KIT near flammable liquids or gases such as gasoline or hydrogen sulfide. Doing so creates a fire hazard.

Installation Method

1. Remove the cover of 24V INTERFACE KIT
Remove the four screws of 24V INTERFACE KIT with a screwdriver or similar tool. Along the hem rotating separation lifted the lid.

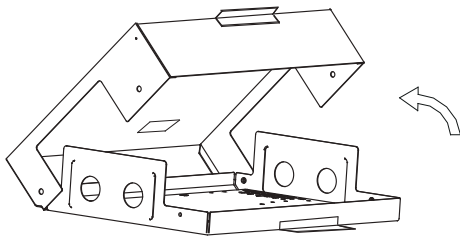

Fig. 2

Minimum free space required around the kit is 7" (180 mm).

2. Mount the back plate of the 24V INTERFACE KIT

Mount 24V INTERFACE KIT vertically, and folding in on, fasten the back plate to the wall with 3 screws (M4x20) and anchors.

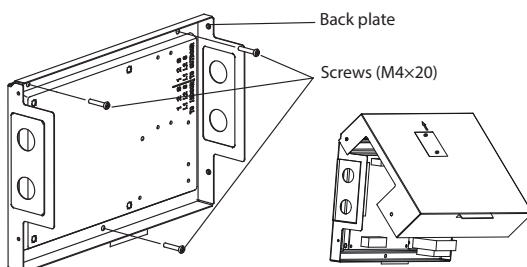

Fig. 3

NOTE:

- Place the unit on a flat surface. Be careful not to distort the back plate of the 24V INTERFACE KIT by over tightening the screws.
- When installed vertically, the direction of the arrow must be up.

3. Wiring.

4. Cover the 24V INTERFACE KIT lid, locking screw.

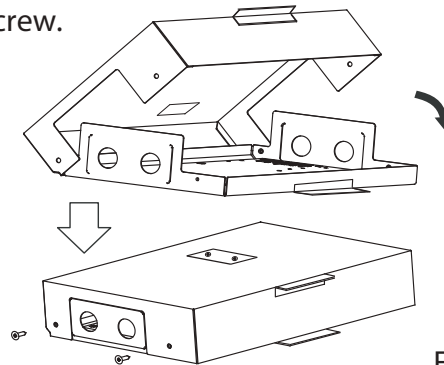

Fig. 4

System Configuration

NOTE:

- Thermostat should be configured for use with a conventional system.
- The remote controller, wiring controller, central controller and WiFi can not be used with this control box at the same time. Only the Swing and LED function can be used.

Connection wiring specification

Conncetion wiring	Outdoor 1,2,3	Indoor 1,2,3	R,C	Y/W/G/G1/G2/G3/Dry
Size	Refer to outdoor connecting wires size	Refer to indoor connecting wires size	18AWG (minimum)	24AWG (minimum)

Application

- * This system is designed for operation with standard 24 vac HVAC thermostats.
- * Wifi standard configuration HVAC thermostats may be used such as NEST, Ecobee, Honeywell, etc.

SYSTEM CONFIGURATION SCENARIOS

Four application scenarios

Scenario No. 1:

Current loop (L1/L2/S or 1/2/3) communication inverter outdoor unit match with other conventional brand 24V indoor unit;

Match with following outdoor units :

- Wall Mounted (Sizes 9K~36K)
- Cassette (Sizes 9K~24K)
- Ducted (Sizes 9K~24K)
- Console (Sizes 9K~12K)
- Floor ceiling (Sizes 18K-24K)

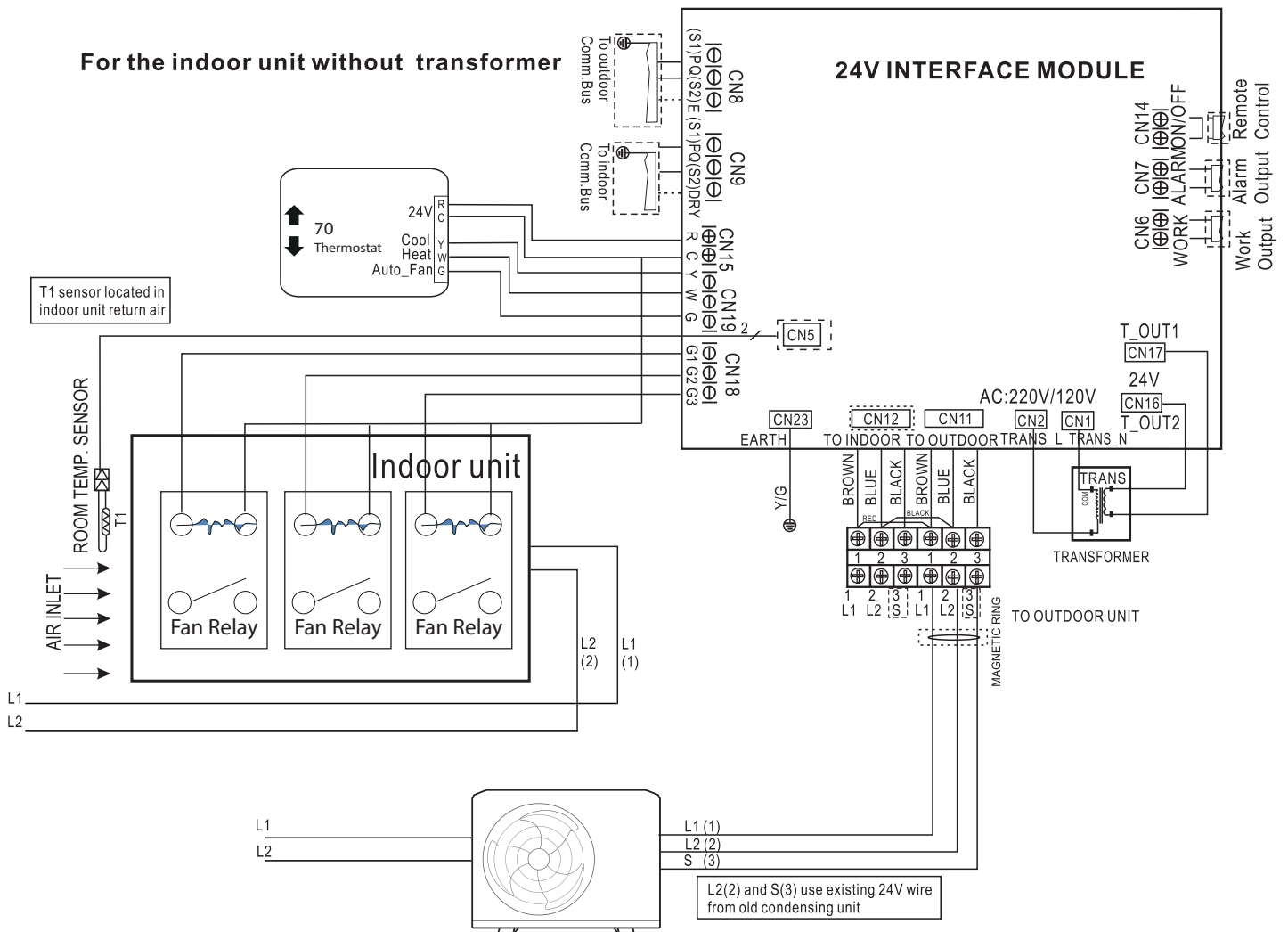

NOTE:

- T1(Room temperature) sensor should be located in the air inlet side.
- Must remove the TXV or other metering device from the indoor unit.

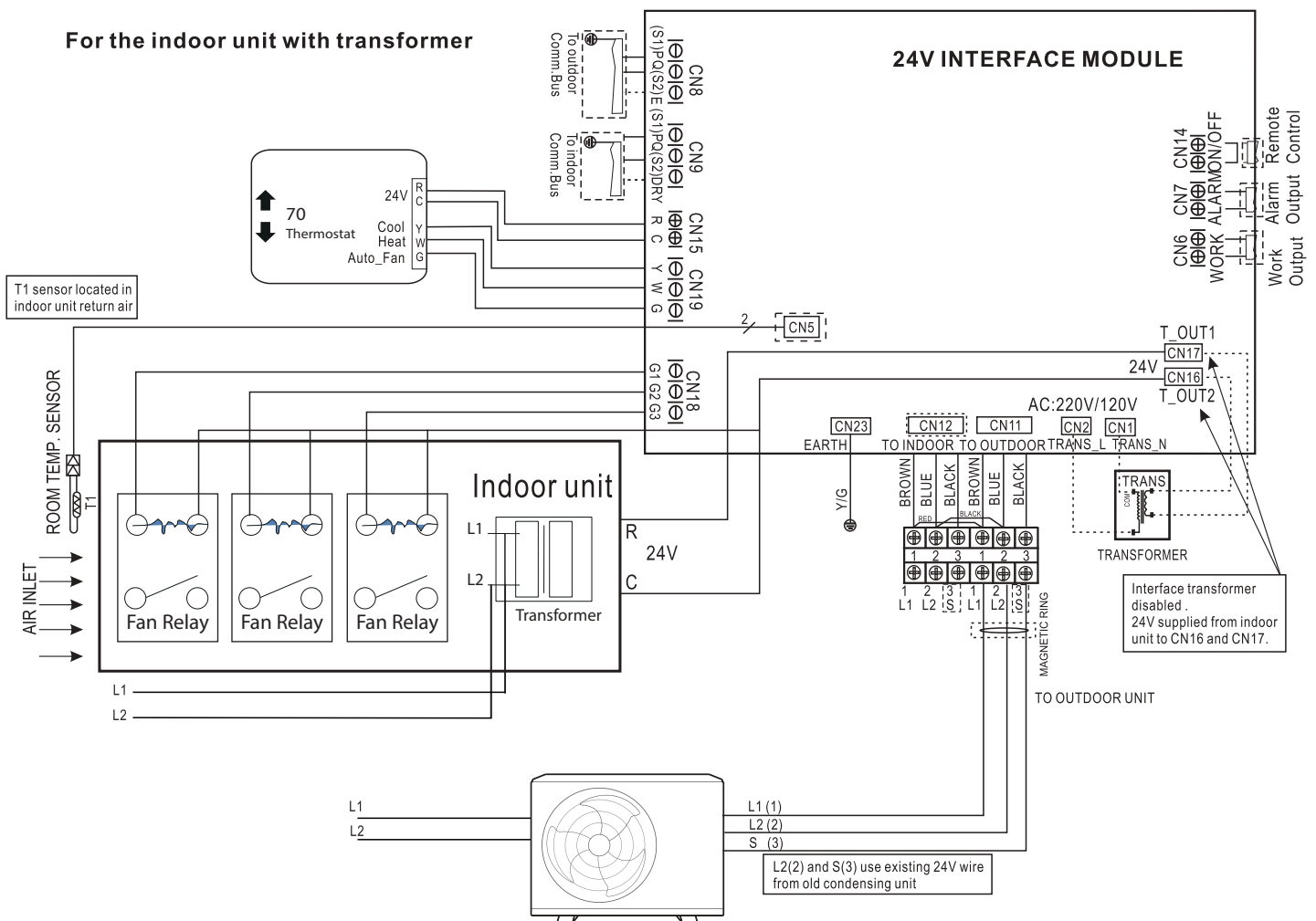

Scenario No. 2:

485 (P Q) or (S1 S2) communication inverter outdoor unit match with conventional other brand 24V indoor unit;

Match with following outdoor units :

- Cassette (Sizes 36K~48K)
- Ducted (Sizes 36K~60K)
- Floor ceiling (Sizes 36K-60K)

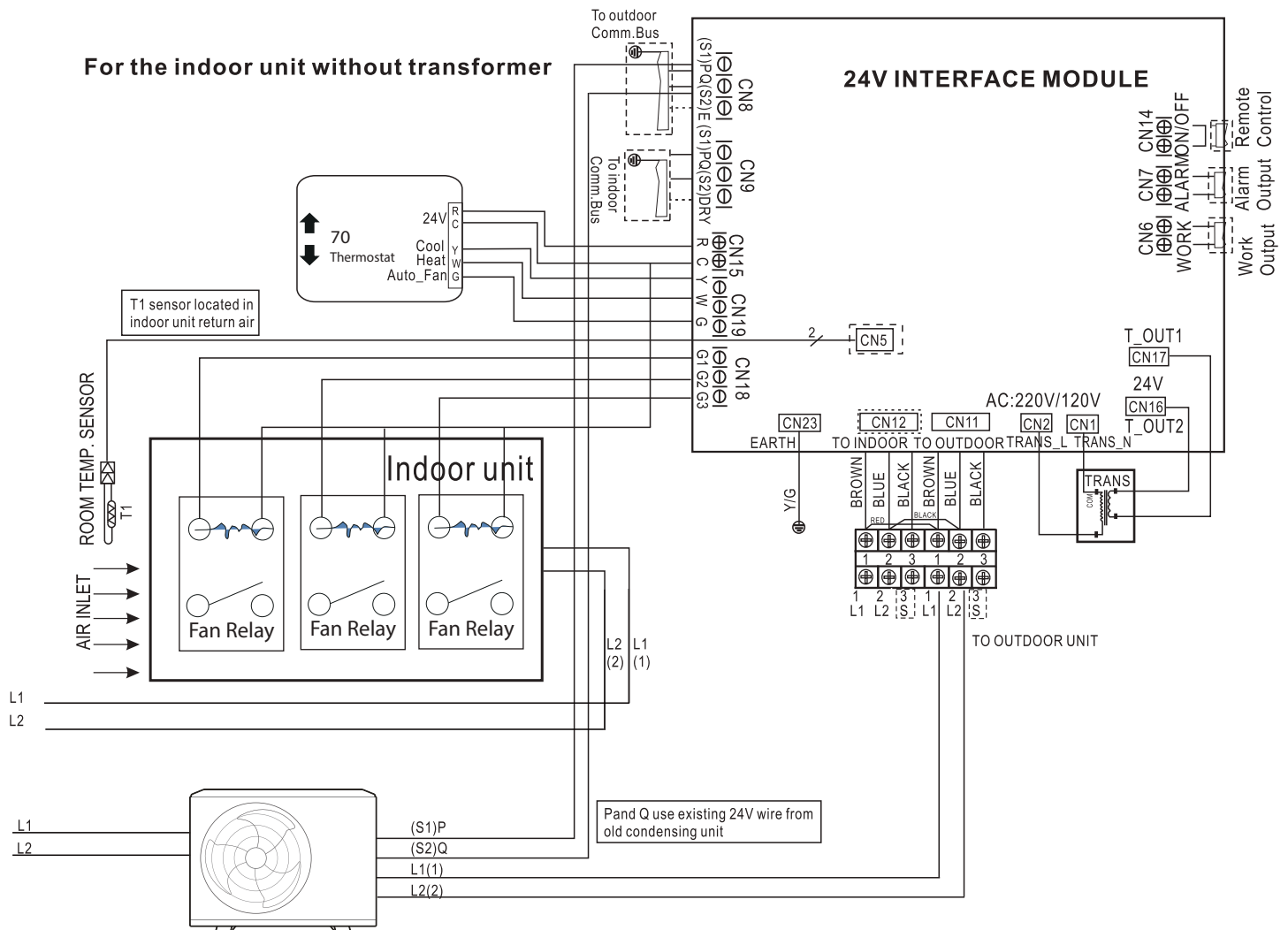

NOTE:

- T1 (Room temperature) sensor should be located in the air inlet side.
- Must remove the TXV or other throttling device from the indoor.

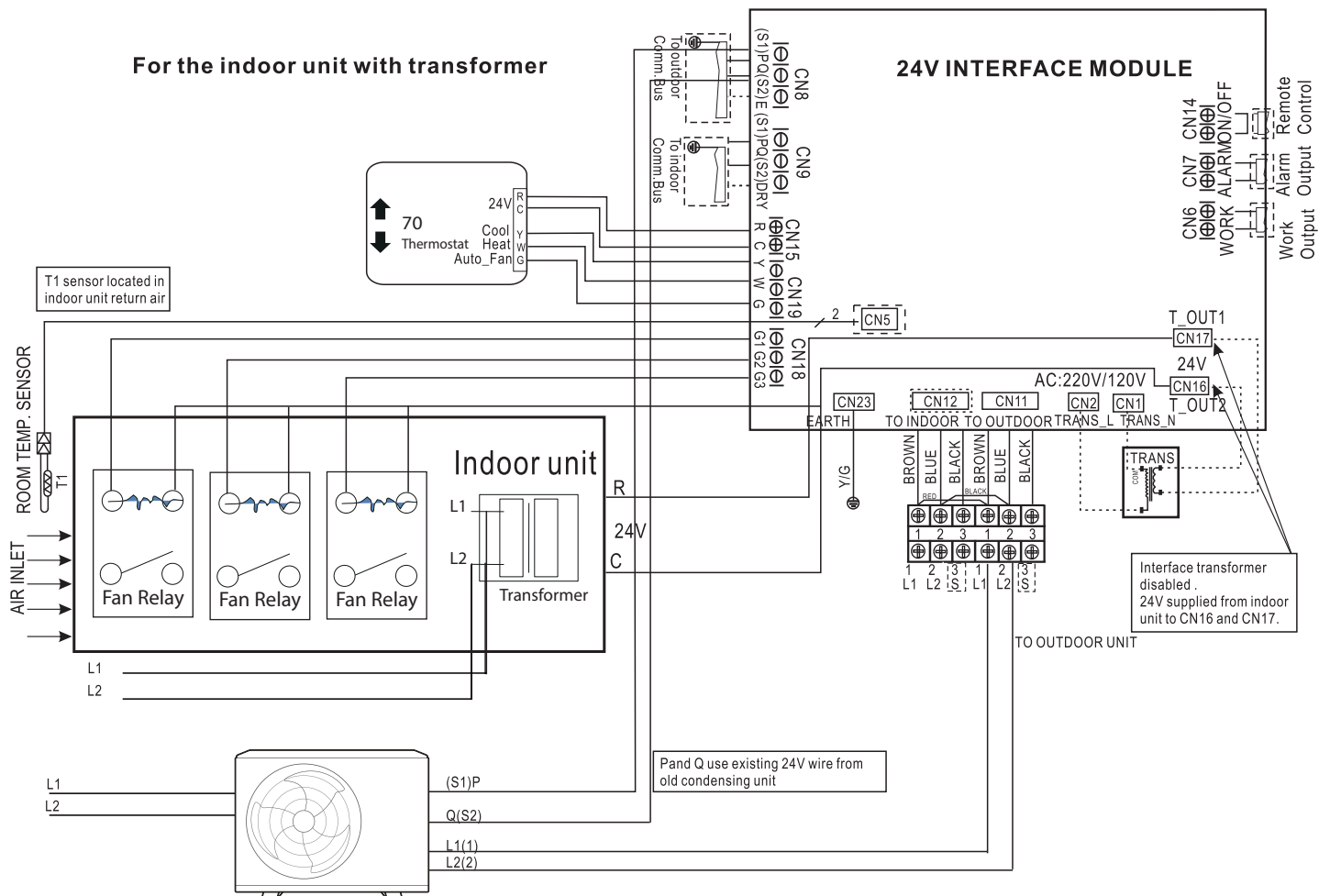

NOTE:

- T1(Room temperature) sensor should be located in the air inlet side.
- Must remove the TXV or other throttling device from the indoor.

- If the indoor unit already has a 24V transformer, removing the transformer from the interface or disconnect the transformer of the interface.

Scenario No. 3:

Current loop (L1 L2 S or 1 2 3) inverter outdoor unit match with current loop inverter indoor unit ;

Match the following indoor units with the corresponding compatible SINGLE ZONE and multi zone outdoor units:

- Wall Mounted (Sizes 9K~36K)
- Cassette (Sizes 9K~24K)
- Ducted (Sizes 9K~24K)
- Console (Sizes 9K~12K)
- Floor ceiling (Sizes 18K-24K)
- Multi system (2 zone, 3 zone, 4 zone, 5 zone)

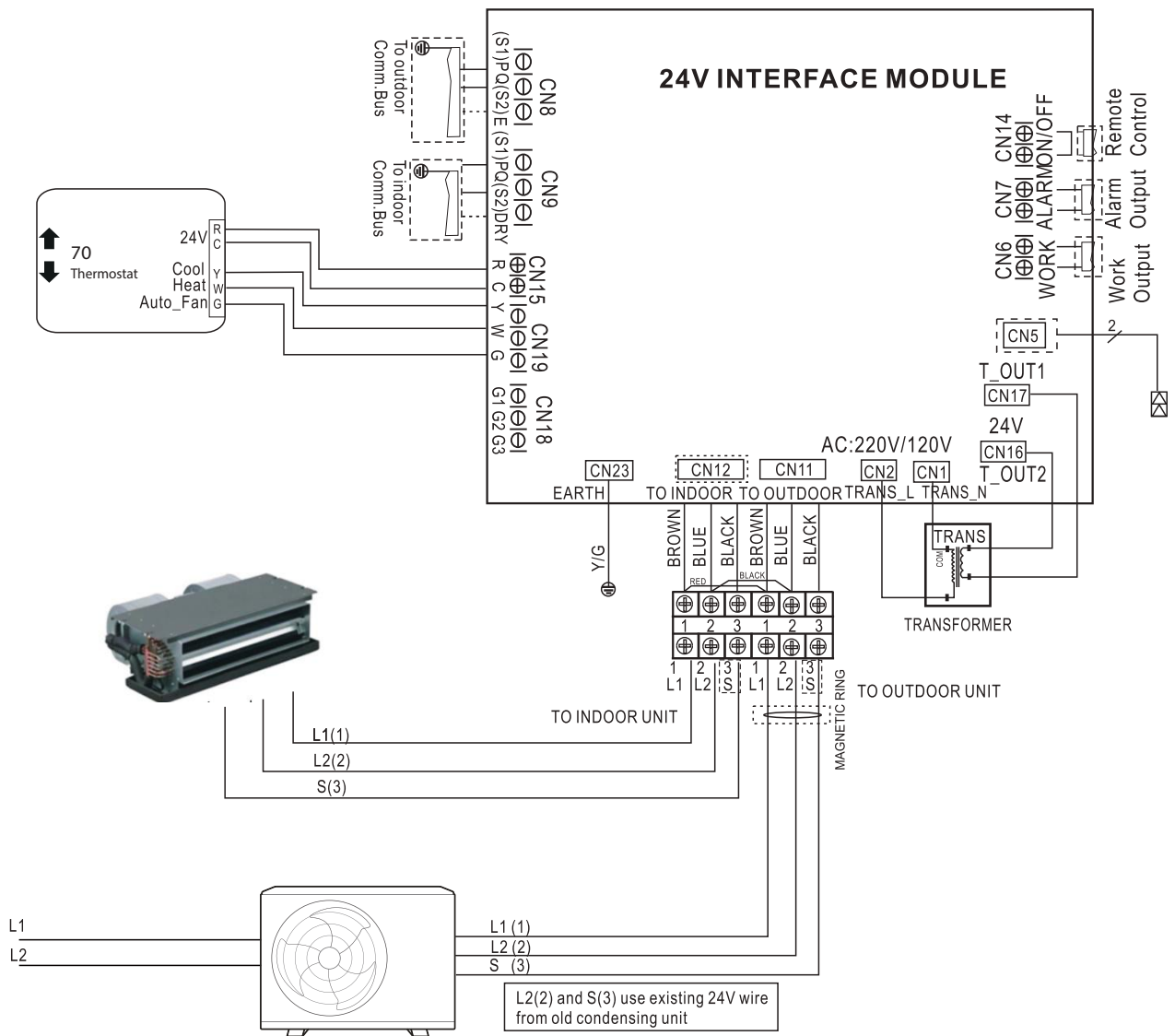

NOTE:

- Please connect thermostat G to 24V interface G as default.
- Make sure the power supply is correct.

- For Wall Mounted unit ,the up-down swing louver and the display on/off function is available by the wireless remote controller.
- Remove 24V control box T1 sensor when match with indoor unit , which has T1 sensor.

Scenario No. 4:

485 (P Q) or (S1 S2) inverter outdoor unit match with 485 inverter indoor unit ;

Match the following indoor units with the corresponding compatible SINGLE ZONE outdoor units:

- Cassette (Sizes 36K~48K)
- Ducted (Sizes 36K~60K)
- Floor ceiling (Sizes 36K-60K)

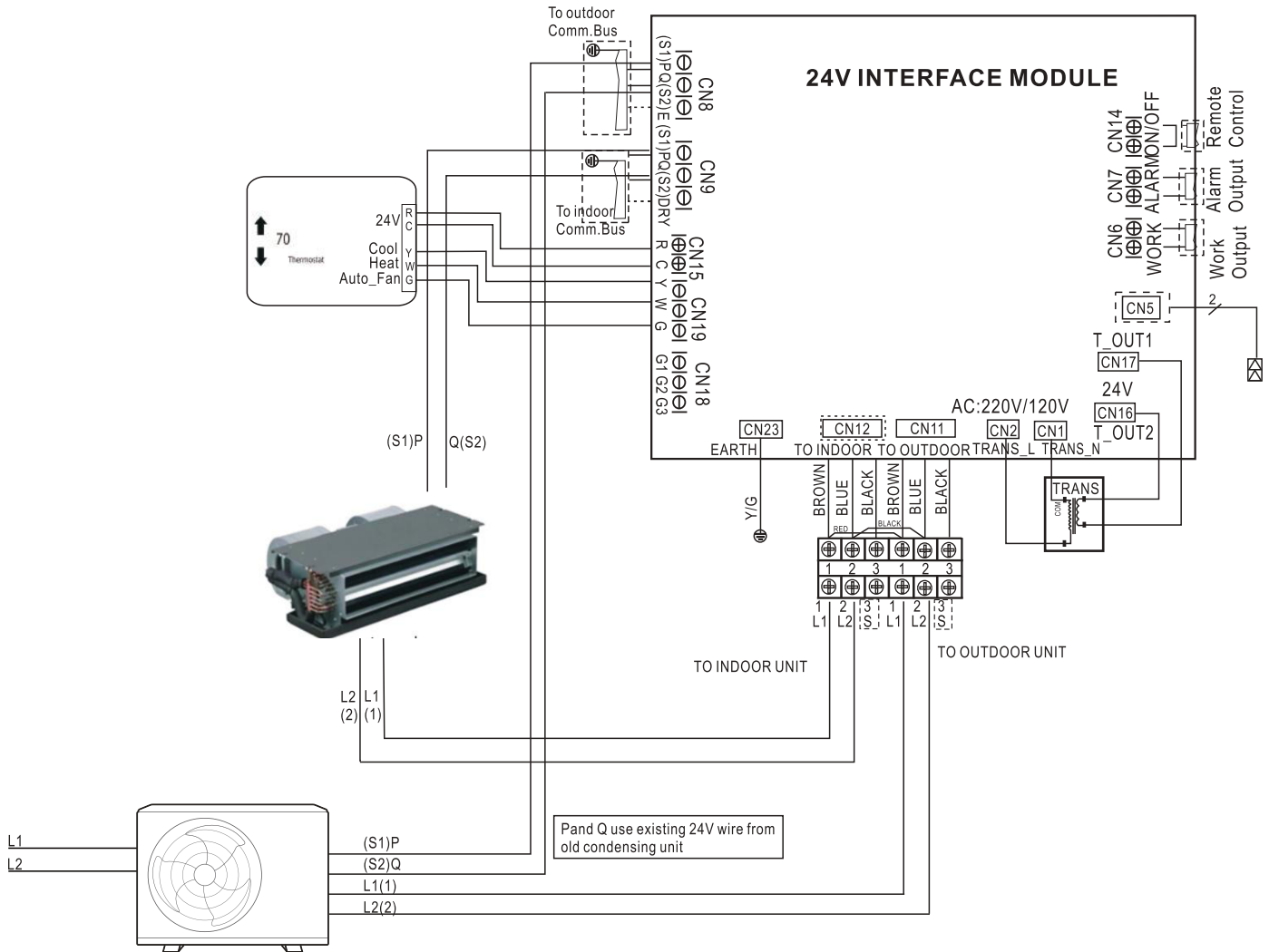

NOTE:

- Please connect thermostat G to 24V interface G as default.

- Make sure the power supply is correct.
- Remove 24V control box T1 sensor when match with indoor unit, which has T1 sensor.



Key Considerations

- The following steps should be taken when using this device with a conventional central air conditioning unit:
 - * Indoor coil metering device must be removed.
 - * 24V transformer in the interface module must be disconnected.
 - * Refrigerant charge amount may need to be adjusted, depending on the pipe size and length, see outdoor recharge instruction.
 - * The maximum air flow should not exceed 400 CFM/Ton.
- When the indoor air handler or furnace has its own 24 vac transformer, you must disconnect all four wires of the kit transformer.

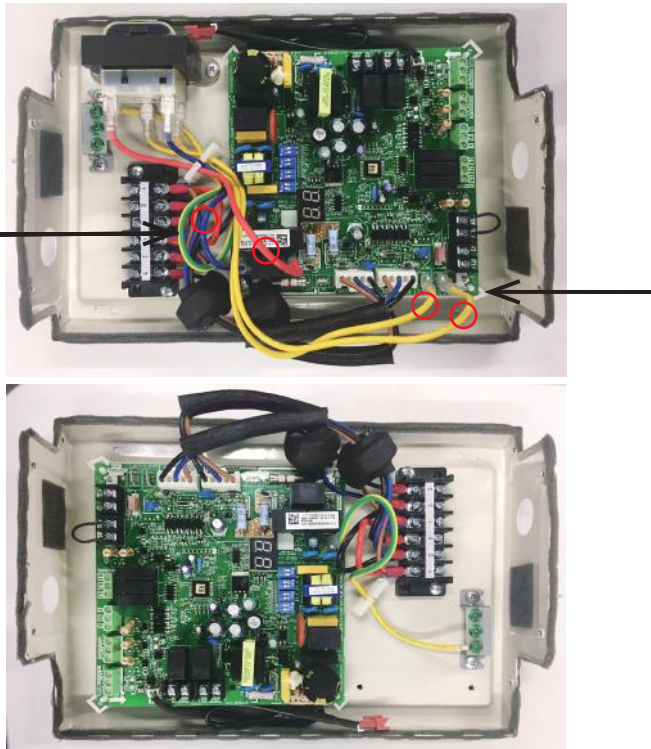

- Suction and liquid refrigerant lines must be properly insulated to prevent condensation and energy loss.
- You must remove the expansion device from an indoor evaporator coil as the refrigerant is controlled by a metering device in the outdoor unit.
- The following steps should be taken when using this device with a Hi wall (9K-36K Btu/hr) Cassette, Console, Duct, Floor Ceiling (9K - 24K Btu/hr).

- Power switch on new board is changed.
- Indoor unit power switch setting, ENC-1 must be changed to the proper motor wattage:
Eg. 36K = 8 48K = 9

Control Logic

Connector

Connector	Purpose
Y	Cooling
W	Heating
G	Fan - Auto speed
AUX/DRY	Aux-Heat/Dry

Mode setting

Y	W	G	Aux/Dry	Setting mode
√	X	*	*	Cooling
X	√	*	X	Heating (without aux-heater)
X	√	*	√	Heating (with aux-heater)
X	X	√	X	Fan only
√	√	*	*	OFF
X	X	X	X	OFF
X	X	*	√(Dry)	Dry
X	X	*	√(AUX)	Emergency heating

Fan speed setting

Unit ON/OFF	G	Setting fan speed
√	X	Auto fan speed
√	√	Auto fan speed
X	X	Fan OFF

√	ON
X	OFF
*	ON or OFF

DIP Switch Definitions

DIP SWITCHES CONFIGURATION

The 24V INTERFACE KIT must be configured to operate properly with the system components with which it is installed. To successfully configure the system move the Dip Switches to match the components and functions used.

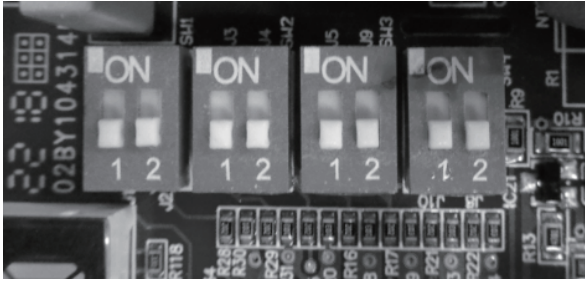

DIP Switch Definitions

Dip Switch 1-1

Used to turn ON or OFF the diagnostic code display LED on the control board of the 24V Interface Kit.

SW1-1	Result	Note
ON	Display on	
OFF	Display off	Default



Dip Switch 1-2

Used for selection of the indoor unit type.

SW1-2	Result	Note
ON	Sets - Both Ductless Indoor and Outdoor Units	
OFF	Outdoor only ----- Compatible with other fix speed 24V control indoor (Wall Hung/ Pancake etc.). Note: 1) Need to remove the indoor unit throttle (piston/ TXV/ orifice); 2) Indoor fan may not stop during the defrost.	Default

NOTE: If this control box is matched with other brand indoor unit, you must set OFF.

Dip Switch 2-1

Used for selection of the system: Cooling Only or Heat Pump.

SW2-1	Result	Note
ON	Cooling only	
OFF	Heat pump	Default

Dip Switch 2-2

Used for freeze protection of the indoor coil.

SW2-2	Result	Note
ON	Fan do not stop	
OFF	Fan will stop if the indoor coil temperature is low	Default

NOTE: Applicable only to Ductless Style Indoor (scenario 3 and 4) Heat Pump units in Heating Mode.

Dip Switch 3-1

Dry is used for thermostats with a Dry Function output. An auxiliary heater is used on the Ducted Style Indoor Units (scenario 3 and 4) to control a secondary Heat Source.

SW3-1	Result	Note
ON	Dry	
OFF	Aux-heater	Default

Dip Switch 3-2

Used to increase the compressor frequency in case the set point has not been reached after 1 hour or 30min of operation.

SW3-2	Result	Note
ON	1h	
OFF	30min	Default

Dip Switch 4-1

SW4-1	Note
OFF	Default

For factory test only.

Dip Switch 4-2

SW4-2	Note
OFF	Default

For factory test only.

Error Codes

Display	Malfunction & protection indication
E0	Indoor EEPROM error
E2	Cross-zero detection error
E3	Indoor fan speed malfunction
E4	Indoor room temperature sensor error
E5	Evaporator coil temperature sensor error
EC	Refrigerant leak detection system malfunction
F0	Current overload protection
F1	Outdoor ambient temperature sensor (T4) malfunction
F2	Condenser coil temperature sensor (T3) malfunction
F3	Condenser coil temperature sensor (T5) malfunction
F4	Outdoor unit EEPROM parameter error
F5	Outdoor fan speed has been out of control
F6	T2b sensor error
P0	Inverter module (IPM) malfunction
P1	Over-voltage or under-voltage protection
P2	Compressor top high temperature protection (OLP)
P3	Low ambient temperature cut off in heating
P4	Compressor drive malfunction
P6	Compressor low-pressure protection
00	Module boot mode and indoor running mode for power off
IN	Module and indoor unit communication malfunction
OU	Module and outdoor unit communication malfunction

Display tube	Set/outdoor only	Unit type	Anti-cold	Aux-heat/dry	Frequency Time	Set/indoor only	Indoor control
SW1-1 Mode OFF ON Factory default >	SW1-2 Mode Outdoor only Set Factory default >	SW2-1 Mode Heat pump only Cooling only Factory default >	SW2-2 Mode YES NO Factory default >	SW3-1 Mode Aux-heat Dry Factory default >	SW3-2 Mode 30min 1H Factory default >	SW4-1 Mode Set/indoor only Factory default >	SW4-2 Mode Fan High Middle Factory default >

NOTE1 : If the SW4-1 is on, the SW4-2 will take effect, otherwise the SW1-2 will take effect.

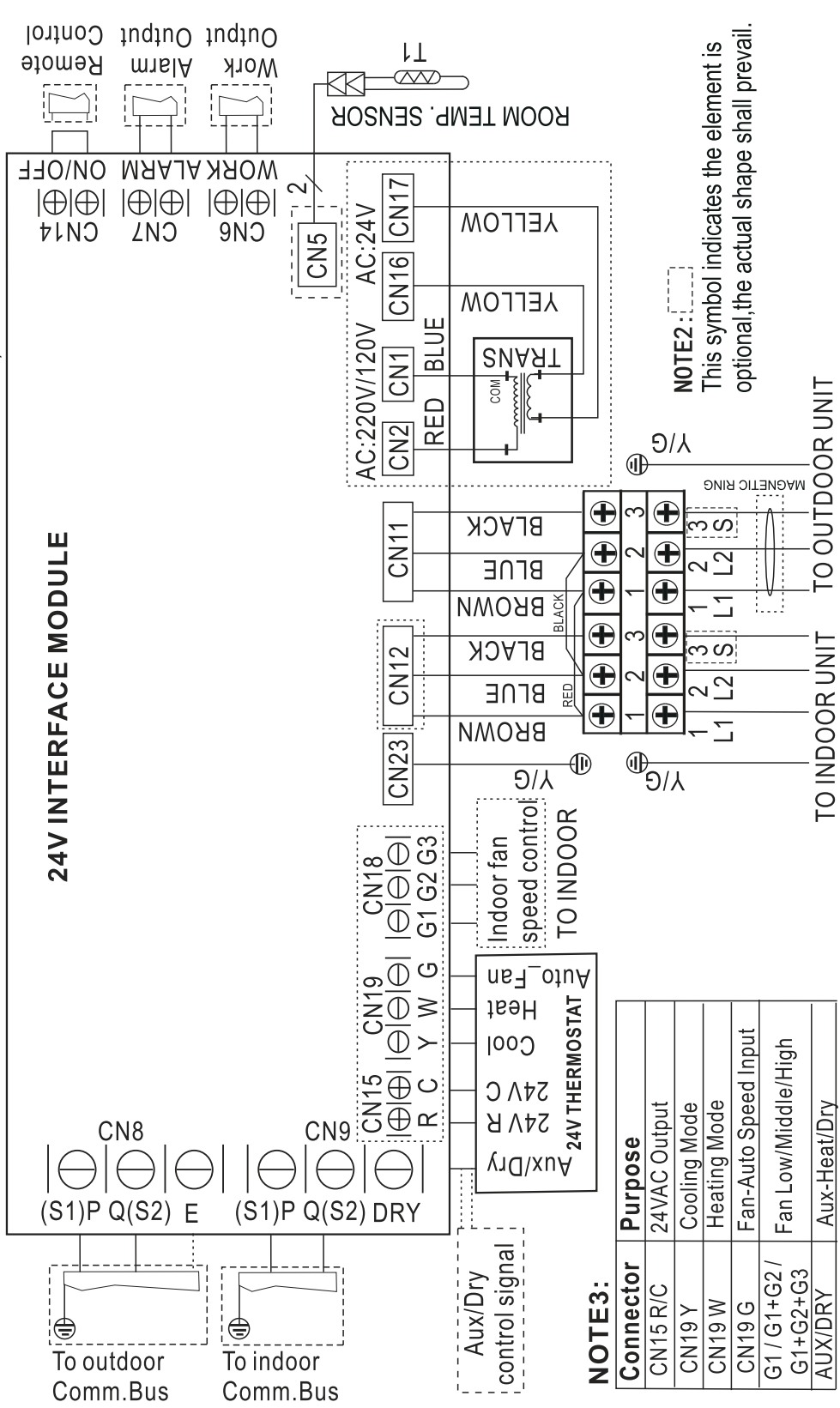

The design and specifications are subject to change without prior notice for product improvement. Consult with the sales agency or manufacturer for details.

QSKZHI-002AEN
16111600000068
20221213

此面无需印刷

技术要求:

1. 双胶纸(说明书)80g非E项目大度
2. 尺寸: 210*297mm
3. 颜色: 黑白
4. 注意: 排版时注意页码数字都是靠外面的, 以便翻阅
5. 装订。

修订

- 1) 改善用户体验, 优化说明书安装配图。2022.12.13