

Job Name:	
Submitted By:	



Submittal Sheet For: YN012GMFI22RPE / CB012GMFILCFHD

Date _____
 Ref. _____

Ceiling Recessed Inverter Driven Heat Pump (1 Ton)

System Full Set Model: **CYB012GMFILCAD**
 AHRI Reference Number: **208191861**

Cooling Mode Performance

Rated Cooling	12000 BTU/hr
Ambient Range	5°F ~ 122°F
SEER Rating	22.0 BTU/W·h
EER Rating	14.0 BTU/W·h

* 100% Capacity @ Indoor DB 80°F/WB 66°F / Outdoor DB 95°F/WB 75°F / m.w. 16"/lineset

Heating Mode Performance

Rated Heating	12000 BTU/hr
Ambient Range	-13°F ~ 86°F
HSPF IV (V)	10.6 (9.8) BTU/W·h
COP	3.37 W/W

* High Heat (47°F) = 12000 BTU / Low Heat (17°F) = 8900 BTU / COP(5°F) = 1.75



Ceiling-Cassette Indoor Unit



Outdoor Condensing Unit



Installation Kit (Pipe+Cable)



Handheld Remote Controller

Electrical Information

Rated Input (W)	Cooling	Heating
	857	1,045
Rated Current (A)	3.92	4.78
Breaker Needed	15A (double-pole)	
Power Supply	208~230V, 1Ph, 60Hz	

Piping and Refrigerant

Liquid Line (OD)	1/4"
Suction Line (OD)	1/2"
Refrigerant Precharge	R410a (10 - 25 ft.)
Max Length/Height Diff.	82 Ft. / 33 Ft.

This combination is Energy-Star® certified.



Interior Unit (Air Handler) Specifications

Airflow Rate (CFM)	335 (Hi) / 280 (Med) / 240 (Lo)
Sound Level (dBA)	40 (Hi) / 36 (Med) / 32.5 (Lo)
Auto Air Circulation	8-Way Louver (4 Sides + 4 Corners)
Dimensions (WDH)	22"-1/2 x 22"-1/2 x 10"-1/4
Weight (Lbs)	35.3 (Handler) / 5.5 (Decorative Panel)

Exterior Unit (Condenser) Specifications

Airflow Rate (CFM)	1,294
Sound Level (dBA)	53.5
Metering Device	Electronic Expansion Valve (EXV)
Compressor	Rotary
Dimensions (WDH)	30"-1/8 x 11"-7/8 x 21"-7/8"
Weight (Lbs)	63.7

CB012GMFILCFHD Air Handler Dimensional Data

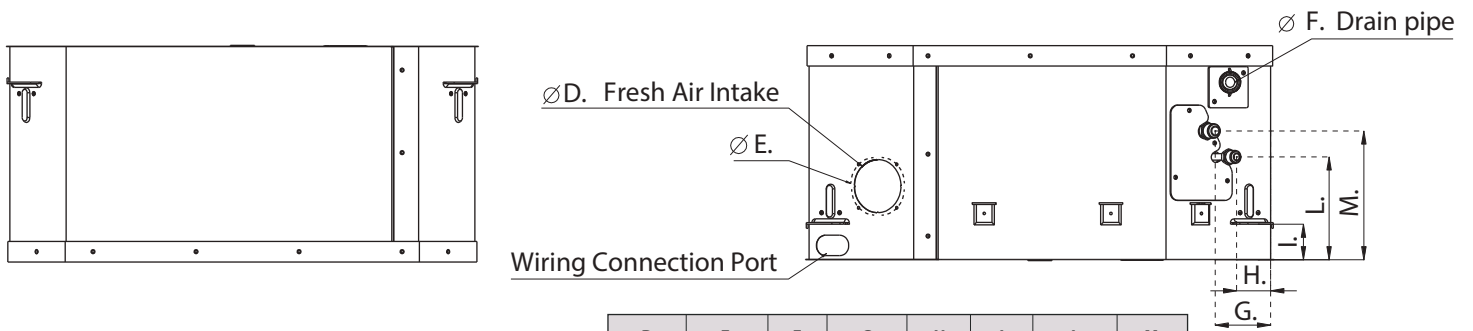

D	E	F	G	H	I	L	M
65 mm	75 mm	25 mm	68 mm	42 mm	44 mm	126 mm	157 mm
2-9/16 in.	25-9/16 in.	1 in.	2-11/16 in.	1-5/8 in.	1-3/4 in.	4-15/16 in.	6-3/16 in.

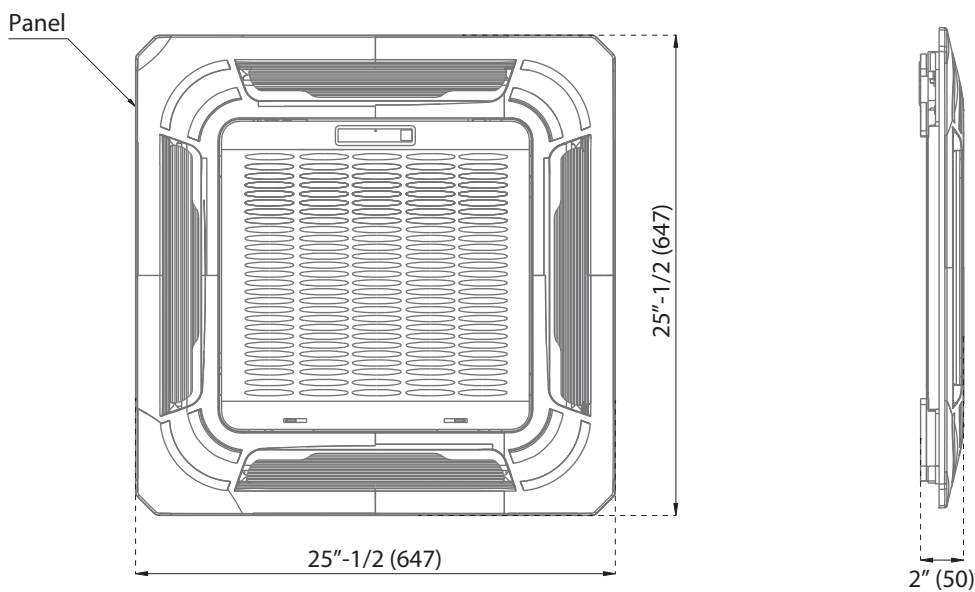
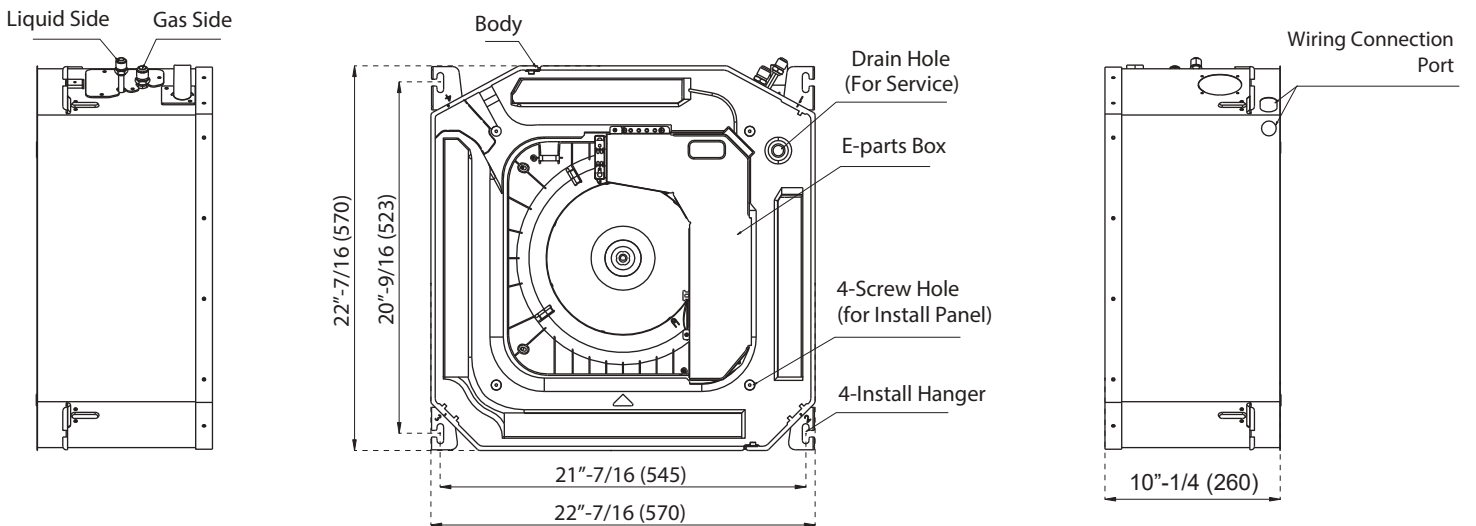

All dimensions are in Inches (mm)

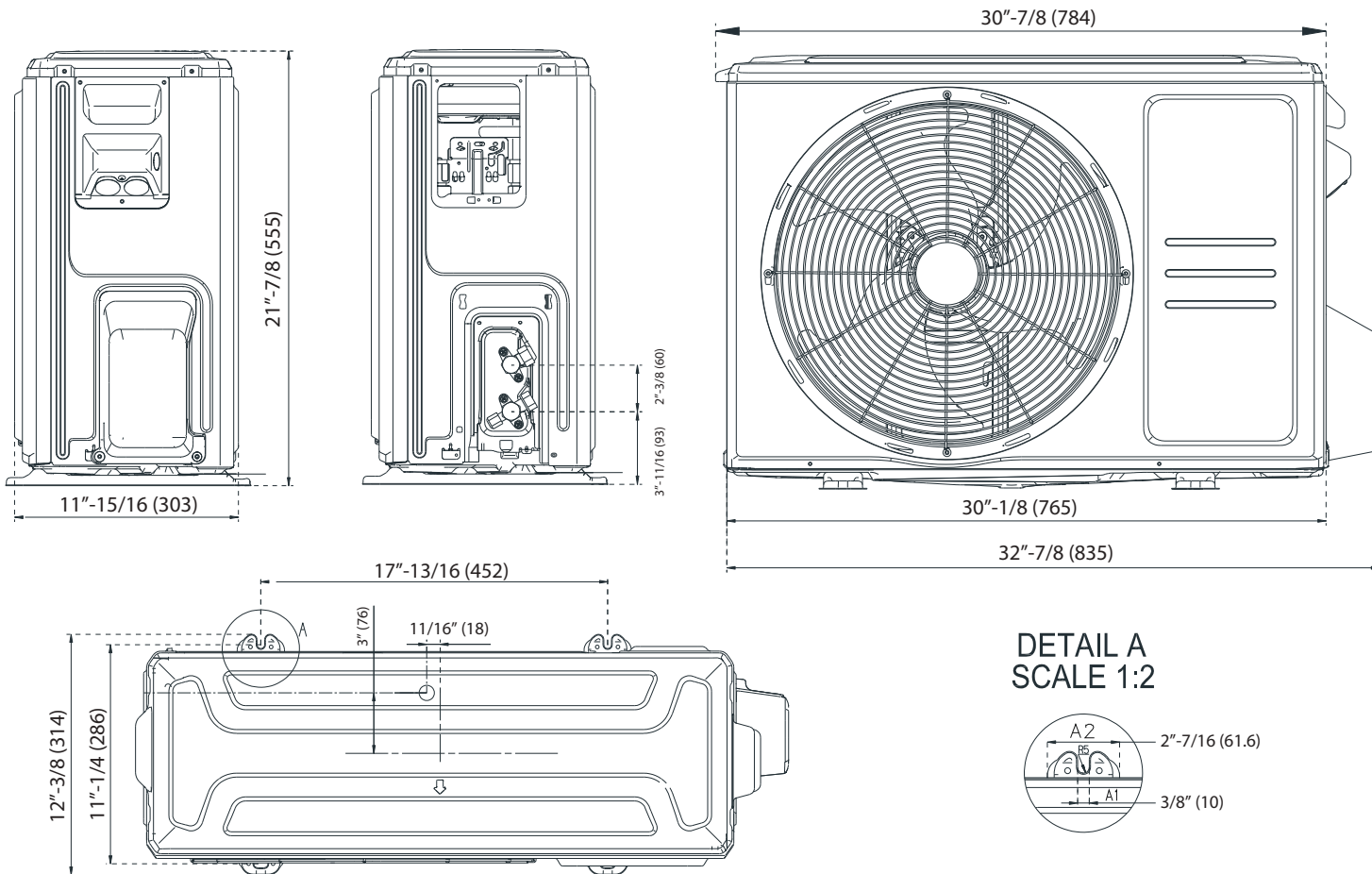

Warranty Information and Length



Complete warranty details are available with the vendor or online at <https://www.pdhvac.com/support/warranty/>. This high quality system is eligible for up to **5** years limited warranty on the compressor, and **5** years on other internal parts. To qualify for this warranty, the system must be installed within 90 days and registered properly. All other installations that are unregistered qualify for only **1** year parts/compressor warranty.

Outstanding Features

- Compact Design
- Fire-Proof Controller Box
- Optional Fresh Air Intake
- Reserved Air Outlet for Duct
- 360° Omni-directional Airflow
- Built-In Condensate Drain Pump
- Decorative Panel/Grille (Included)
- Optional Programmable Controller

Available Accessories

Part Number	Description
IKT-LCVR4P-KIT	<i>Decorative PVC Line Cover Kit</i>
TST-LCACWIFIKP	<i>Smart-WiFi Wired Wall Thermostat Kit</i>
BRK-FRM-C-2P	<i>Folding Mounting Bracket w/ Leveler</i>
IKT-UVL32UL-AG	<i>UVC Bacterial Disinfection Kit</i>
@ICM517	<i>Ultimate Surge and Power Protection</i>