

Job Name:	
Submitted By:	



Submittal Sheet For: YN009GMFI22RPE / CK009GMFILCFHD

Date _____
 Ref. _____

One-Way Cassette Inverter Driven Heat Pump (0.75 Ton)

System Full Set Model: **CYK009GMFILCAD**
 AHRI Reference Number: **213349746**

Cooling Mode Performance

Rated Cooling	9000 BTU/hr
Ambient Range	5°F ~ 122°F
SEER2 Rating	22.5 BTU/W·h
EER2 Rating	13.0 BTU/W·h

*100% Capacity @ Indoor DB 80°F/WB 66°F / Outdoor DB 95°F/WB 75°F / m.w. 16'lineset

Heating Mode Performance

Rated Heating	11000 BTU/hr
Ambient Range	-13°F ~ 86°F
HSPF IV (V)	11.5 (9.1) BTU/W·h
C.O.P.	3.44 W/W

*Med Heat (17°F) = 8000 BTU / Low Heat (5°F) = 7700 BTU / COP(5°F) = 2.34



Single-Way Cassette Indoor Unit



Outdoor Condensing Unit



Installation Kit (Pipe+Cable)



Handheld Remote Controller

Electrical Information

Rated Input (W)	Cooling	Heating
	692	938
Rated Current (A)	3.10	4.26
Breaker Needed	15A (double-pole)	
Power Supply	208~230V, 1Ph, 60Hz	

Piping and Refrigerant

Liquid Line (OD)	1/4"
Suction Line (OD)	3/8"
Refrigerant Precharge	R410a (10 - 25 ft.)
Max Length/Height Diff.	82 Ft. / 33 Ft.

This combination is Energy-Star® certified.



Interior Unit (Air Handler) Specifications

Airflow Rate (CFM)	341 (T) / 294 (Hi) / 259 (Md) / 235 (Lo)
Sound Level (dBA)	38 (Hi) / 36 (Med) / 33 (Lo)
Auto Air Circulation	1-Way Louver (Auto Up-Down Swing)
Dimensions (WDH)	50"-1/4 x 13"-1/4 x 9" (Air Handler)
Weight (Lbs)	44 (Handler) / 24 (Decorative Panel)

Exterior Unit (Condenser) Specifications

Airflow Rate (CFM)	1,294
Sound Level (dBA)	54
Metering Device	Electronic Expansion Valve (EXV)
Compressor	Rotary
Dimensions (WDH)	30"-1/8 x 11"-7/8 x 21"-7/8"
Weight (Lbs)	63.7

CK009GMFILCFHD Air Handler Dimensional Data

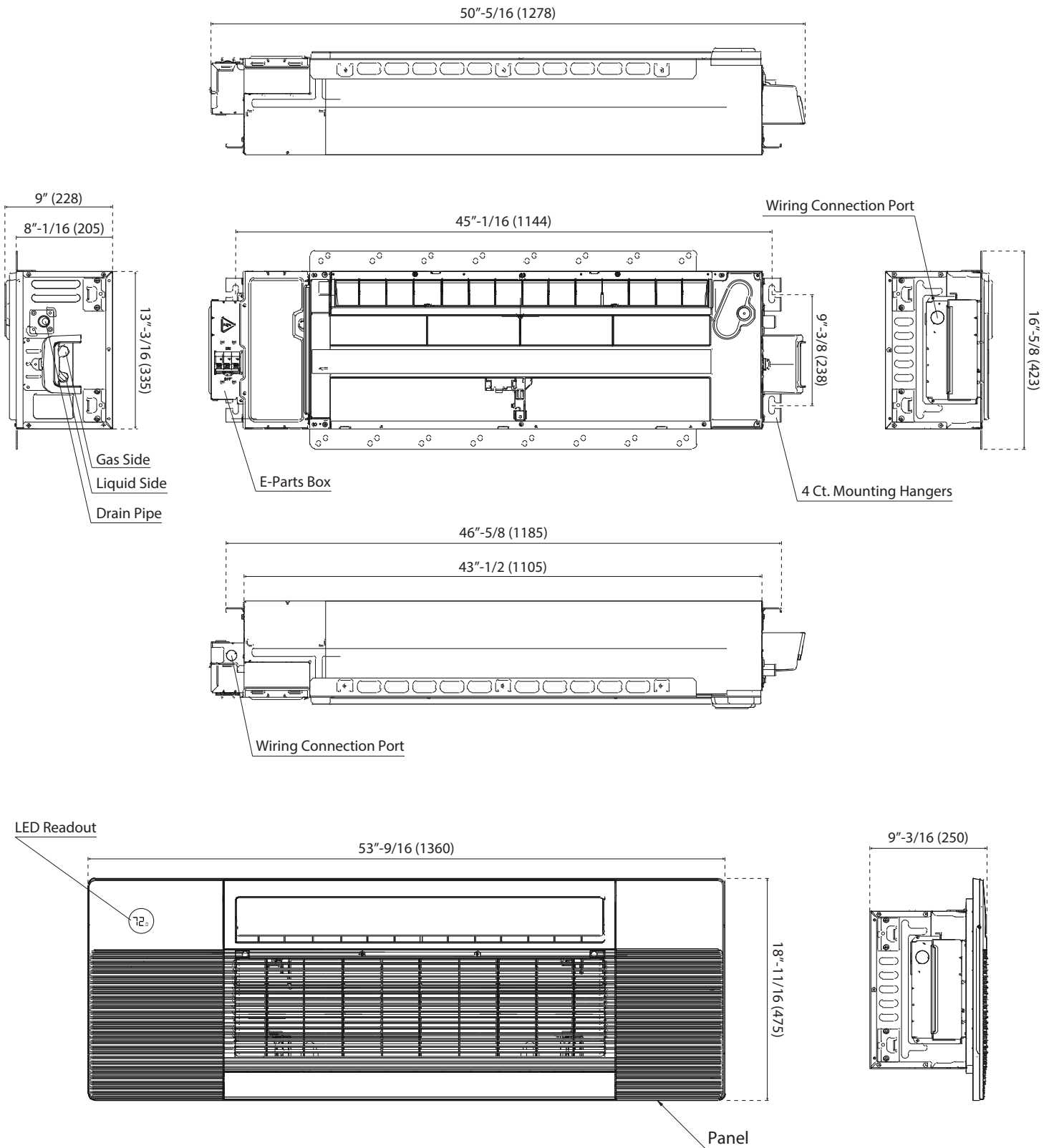

All dimensions are in Inches (mm)

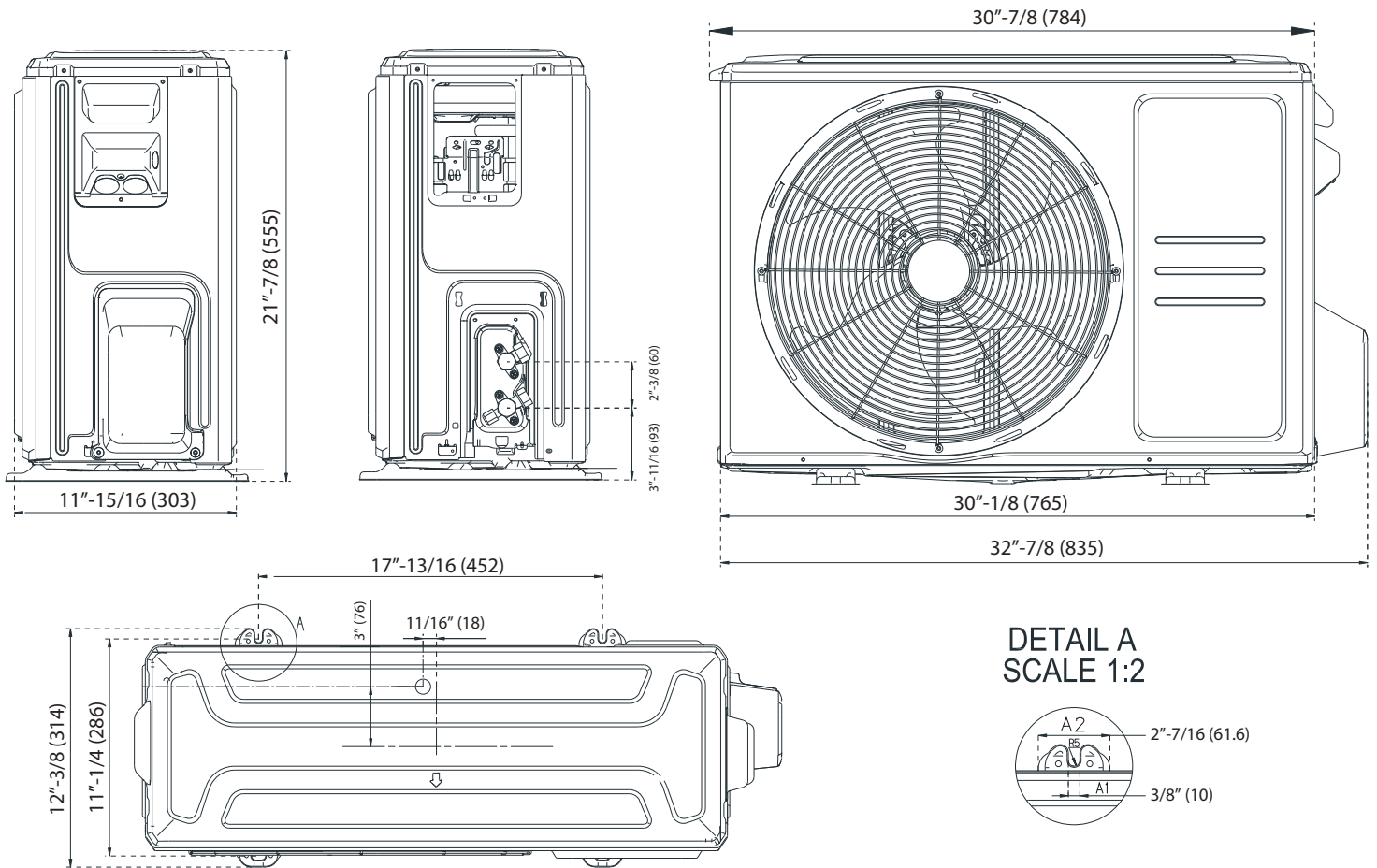

Warranty Information and Length



Complete warranty details are available with the vendor or online at <https://www.pdhvac.com/support/warranty/>. This high quality system is eligible for up to **5** years limited warranty on the compressor, and **5** years on other internal parts. To qualify for this warranty, the system must be installed within 90 days and registered properly. All other installations that are unregistered qualify for only **1** year parts/compressor warranty.

Outstanding Features

- Attractive LED Display
- Easy-Open Front Panel
- Auto-lowering Air Filter Panel
- Over or Under Beam Installation
- Slim Design Fits Between Trusses
- Built-In Condensate Drain Pump
- Decorative Panel/Grille (Included)
- Optional Programmable Controller

Available Accessories

Part Number	Description
IKT-LCVR4P-KIT	<i>Decorative PVC Line Cover Kit</i>
TST-APWIFIMUSB	<i>Internet Access and Control Module</i>
BRK-FRM-C-2P	<i>Folding Mounting Bracket w/ Leveler</i>
IKT-UVL32UL-AG	<i>UVC Bacterial Disinfection Kit</i>
@ICM517	<i>Ultimate Surge and Power Protection</i>