

Job Name:	
Submitted By:	



**Submittal Sheet For:** **YN018GMFI22RPE / CK018GMFILCFHD**

Date \_\_\_\_\_  
 Ref. \_\_\_\_\_

**One-Way Cassette Inverter Driven Heat Pump (1.5 Ton)**

System Full Set Model: **CYK018GMFILCAD**  
 AHRI Reference Number: **213349744**

**Cooling Mode Performance**

Rated Cooling	18000 BTU/hr
Ambient Range	5°F ~ 122°F
SEER2 Rating	21.8 BTU/W·h
EER2 Rating	12.5 BTU/W·h

\*100% Capacity @ Indoor DB 80°F/WB 66°F / Outdoor DB 95°F/WB 75°F / m.w. 16'lineset

**Heating Mode Performance**

Rated Heating	19000 BTU/hr
Ambient Range	-13°F ~ 86°F
HSPF IV (V)	10.7 (7.6) BTU/W·h
C.O.P.	3.30 W/W

\*Med Heat (17°F) = 12200 BTU / Low Heat (5°F) = 13100 BTU / COP(5°F) = 2.3



Single-Way Cassette Indoor Unit



Outdoor Condensing Unit



Installation Kit (Pipe+Cable)



Handheld Remote Controller

**Electrical Information**

Rated Input (W)	Cooling	Heating
	1440	1690
Rated Current (A)	6.4	7.6
Breaker Needed	20A (double-pole)	
Power Supply	208~230V, 1Ph, 60Hz	

**Piping and Refrigerant**

Liquid Line (OD)	1/4"
Suction Line (OD)	1/2"
Refrigerant Precharge	R410a (10 - 25 ft.)
Max Length/Height Diff.	98 Ft. / 66 Ft.

This combination is Energy-Star® certified.



**Interior Unit (Air Handler) Specifications**

Airflow Rate (CFM)	400 (T) / 352 (Hi) / 300 (Md) / 207 (Lo)
Sound Level (dBA)	44 (Hi) / 41 (Med) / 34 (Lo)
Auto Air Circulation	1-Way Louver (Auto Up-Down Swing)
Dimensions (WDH)	50"-1/4 x 13"-1/4 x 9" (Air Handler)
Weight (Lbs)	45 (Handler) / 24 (Decorative Panel)

**Exterior Unit (Condenser) Specifications**

Airflow Rate (CFM)	2,058
Sound Level (dBA)	58
Metering Device	Electronic Expansion Valve (EXV)
Compressor	Rotary
Dimensions (WDH)	35" x 13"-1/2 x 26-1/2"
Weight (Lbs)	94.4

# CK018GMFILCFHD Air Handler Dimensional Data

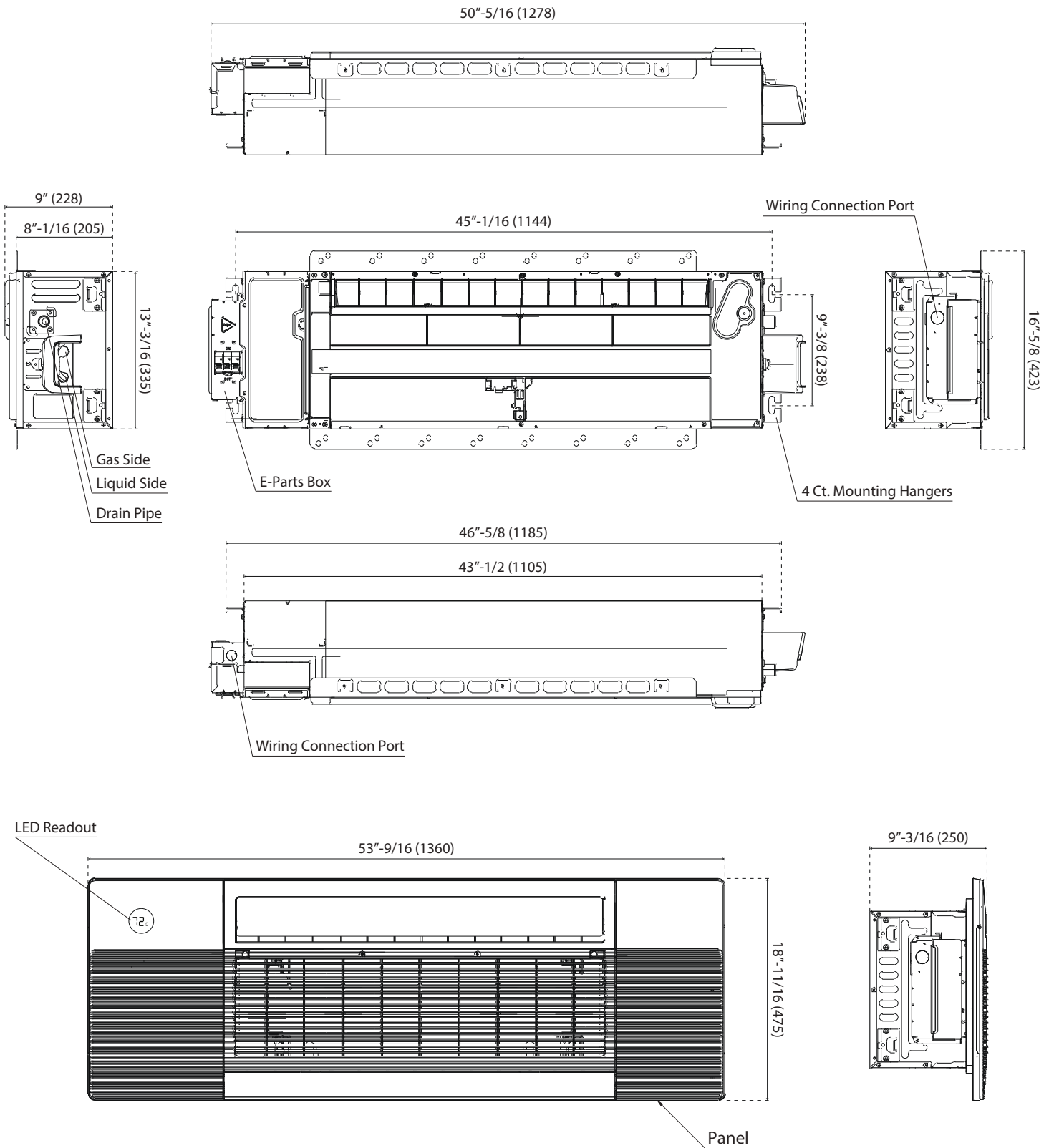

All dimensions are in Inches (mm)

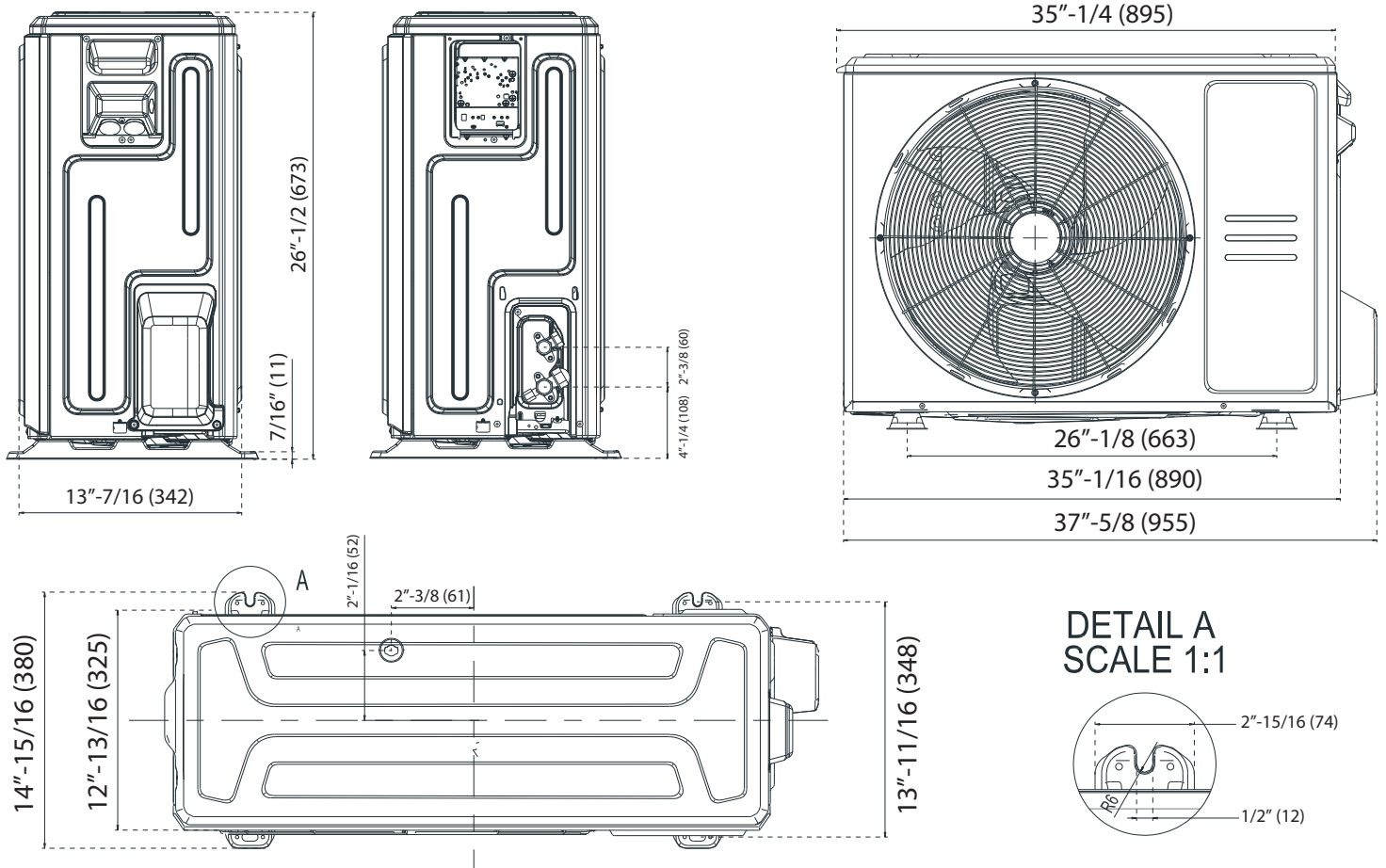

### Warranty Information and Length



Complete warranty details are available with the vendor or online at <https://www.pdhvac.com/support/warranty/>. This high quality system is eligible for up to **5** years limited warranty on the compressor, and **5** years on other internal parts. To qualify for this warranty, the system must be installed within 90 days and registered properly. All other installations that are unregistered qualify for only **1** year parts/compressor warranty.

### Outstanding Features

- Attractive LED Display
- Easy-Open Front Panel
- Auto-lowering Air Filter Panel
- Over or Under Beam Installation
- Slim Design Fits Between Trusses
- Built-In Condensate Drain Pump
- Decorative Panel/Grille (Included)
- Optional Programmable Controller

### Available Accessories

Part Number	Description
IKT-LCVR4P-KIT	Decorative PVC Line Cover Kit
TST-APWIFIMUSB	Internet Access and Control Module
BRK-FRM-C-2P	Folding Mounting Bracket w/ Leveler
IKT-UVL32UL-AG	UVC Bacterial Disinfection Kit
@ICM517	Ultimate Surge and Power Protection