

Job Name:	
Submitted By:	



Submittal Sheet For: YH1824GHFD18R2 / DR024GHFD18HT2

Date _____
 Ref. _____

Ducted Central Inverter Split AC Heat Pump (2 Ton)

System Full Set Model: **DYR1824GMFI18R**
 AHRI Reference Number: **207028594**

Cooling Mode Performance

Rated Cooling	22000 BTU/hr
Ambient Range	5°F ~ 122°F
SEER2 Rating	16.5 BTU/W·h
EER2 Rating	10.1 BTU/W·h

* 100% Capacity @ Indoor DB 80°F/WB 67°F / Outdoor DB 95°F/WB 75°F / m.w. 25' lineset

Heating Mode Performance

Rated Heating	23000 BTU/hr
Ambient Range	-13°F ~ 75°F
HSPF2 Region IV	9.0 BTU/W·h
COP	3.40 W/W

*High Heat (47°F) = 23000 BTU / Low Heat (17°F) = 16000 BTU / C.O.P. (5°F) = 2.05



Ducted Air Handler Unit



Outdoor Condensing Unit



**optional*

5 kW Heater (w/ breaker)

Electrical Information

Rated Input (W)	Cooling	Heating
	2,380	2,070
Rated Current (A)	11.2	9.4
Breakers Needed	20A + 10A (2-pole)	
Power Supply	208~230V, 1Ph, 60Hz	

Piping and Refrigerant

Liquid Line (OD)	3/8"
Suction Line (OD)	5/8"
Refrigerant Precharge	R410a (10 - 25 ft.)
Max Length/Height Diff.	164 Ft. / 98 Ft.

This combination is certified for the following marks:

Interior Unit (Air Handler) Specifications

Airflow Rate (CFM)	800
Sound Level (dBA)	55.0
Throttle Type	Thermostatic Expansion Valve (TXV)
Dimensions (WDH)	19"-11/16 x 21"-5/8 x 46"-1/16
Weight (Lbs)	135.5

Exterior Unit (Condenser) Specifications

Airflow Rate (CFM)	1,825
Sound Level (dBA)	54.0
Throttle Type	Electronic Expansion Valve (EXV)
Compressor	Twin Rotary
Dimensions (WDH)	33"-7/8 x 12"-3/16 x 26-3/8"
Weight (Lbs)	112.4

DR024GHFD18HT2 Air Handler Dimensional Data

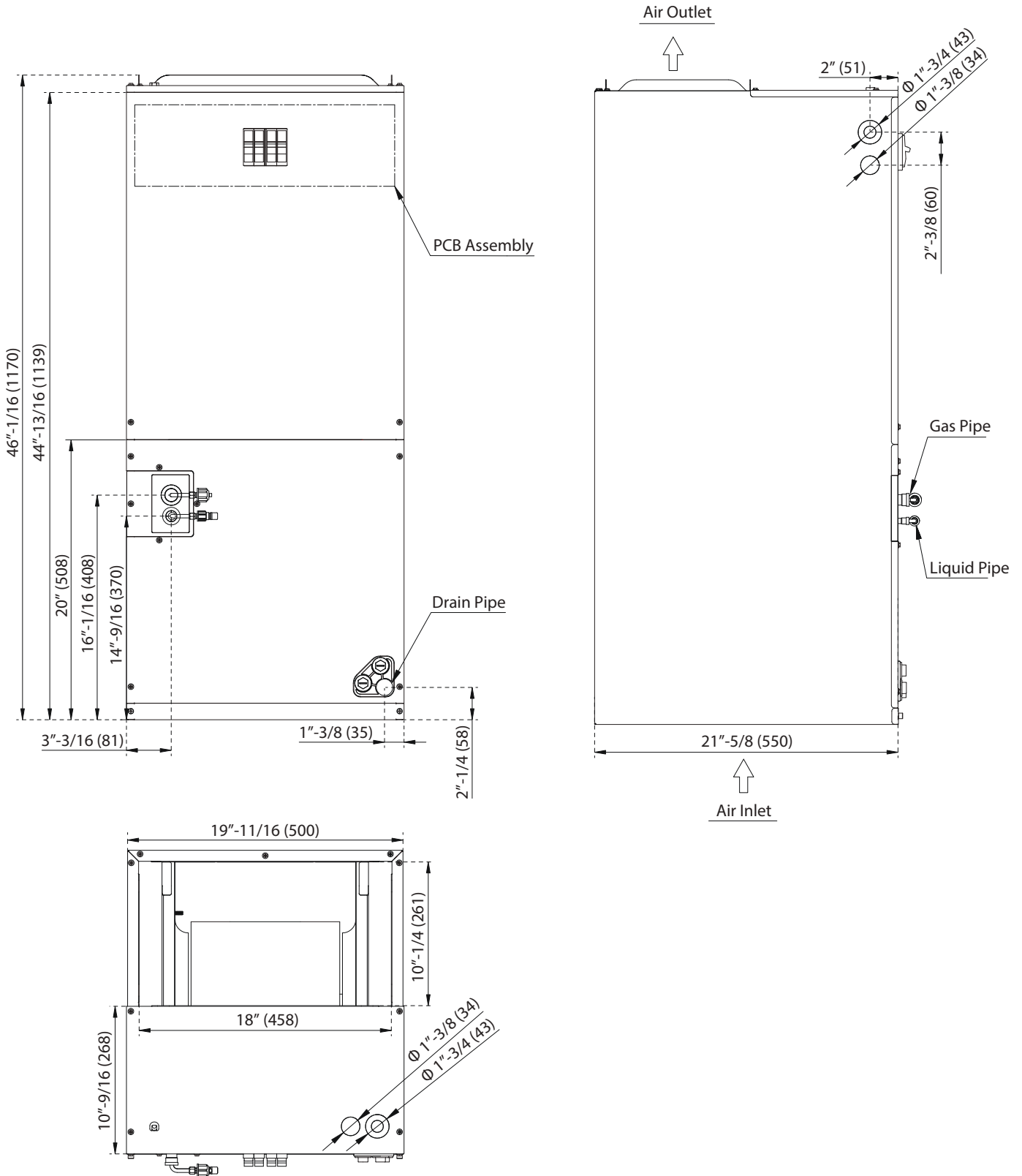

All dimensions are in Inches (mm)

SIDE VIEW

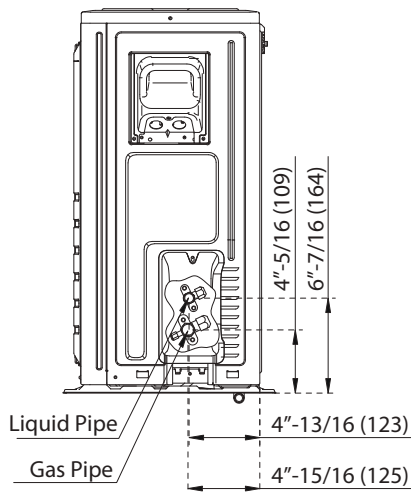

FRONT VIEW

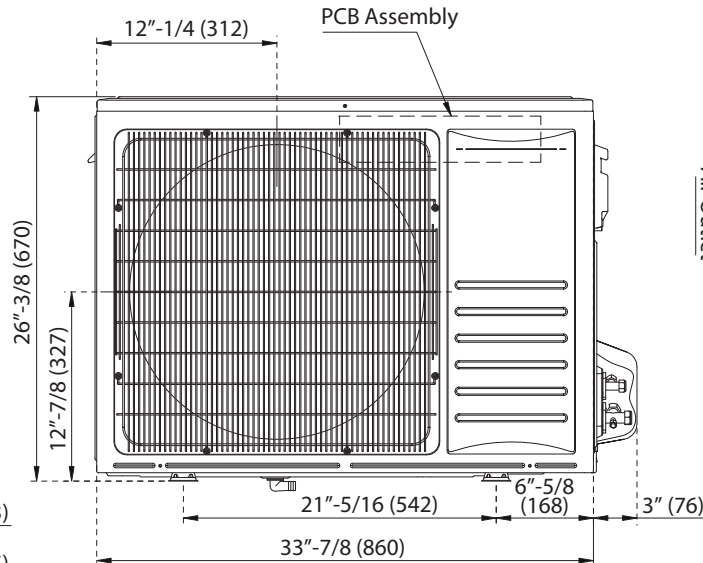

TOP VIEW

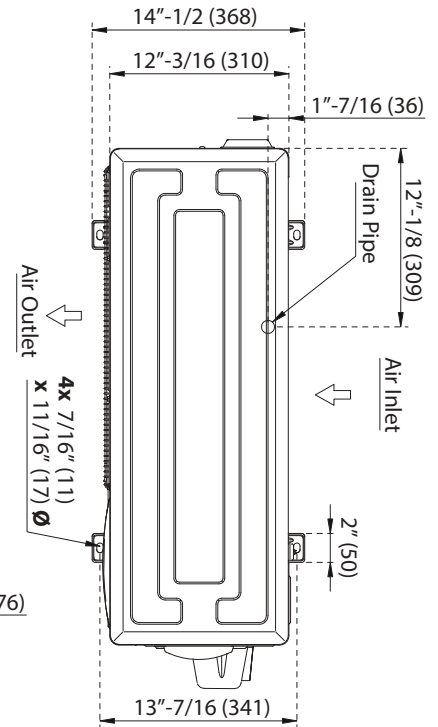

All dimensions are in Inches (mm)

Warranty Information and Length



Complete warranty details are available with the vendor or online at <https://www.pdhvac.com/support/warranty/>. This high quality system is eligible for up to **5** years limited warranty on the compressor, and **5** years on other internal parts. To qualify for this warranty, the system must be installed within 90 days and registered properly. All other installations that are unregistered qualify for only **1** year parts/compressor warranty.

Outstanding Features

- Uses any 24V Heat Pump Thermostat
- Extreme-Ambient Operation Range
- Downflow-Convertible Air Handler
- Communicating AHU+Condenser
- Inverter-Driven Compressor/PCB
- Powerful Static Pressure Output
- Side-Discharge Condenser Unit
- Ultra-Flexible Lineset Routing

Available Accessories

Part Number	Description
IKT-4WID2-LVCR	Decorative Wide PVC Line Cover Kit
BRK-FLR-GS-2P	Floor Stand Ground Mount Bracket
BRK-FRM-C-2P	Folding Mounting Bracket w/ Leveler
WTM0502BX	5kW Electric Heater w/ Breaker
@ICM517	Ultimate Surge and Power Protection