

Job Name:	
Submitted By:	



Submittal Sheet For: YN020GLFI22M2D / (2x) WT0xxGLFI22HLD

Date _____
 Ref. _____

Dual (2) Circuit Inverter Heat Pump Set (1.5 Ton)

Complete Set Model: **WYT020GLHI22M2**
 AHRI Reference Number: **207698162**

Cooling Mode Performance

Rated Cooling	17000 BTU/hr
Ambient Range	5°F ~ 122°F
SEER Rating	22.0 BTU/W·h
EER Rating	12.5 BTU/W·h

* 100% Capacity @ Indoor DB 80°F/WB 66°F / Outdoor DB 95°F/WB 75°F / 16' Linesets

Heating Mode Performance

Rated Heating	19600 BTU/hr
Ambient Range	-4°F ~ 86°F
HSPF IV (V)	10.0 (8.0) BTU/W·h
COP	3.5 W/W

* High Heat (47°F) = 19600 BTU / Low Heat (17°F) = 13700 BTU / COP(5°F) = 1.75



Wi-Fi Enabled

Wall-Mounted Indoor Unit



Outdoor Condensing Unit



Installation Kit (Pipe+Cable)



Handheld Remote Controller

Electrical Information

Rated Input (W)	Cooling	Heating
	1,350	1,600
Rated Current (A)	6.5	7.5
Breaker Needed	15A (double-pole)	
Power Supply	208/230V, 1Ph, 60Hz	

Piping and Refrigerant

Liquid Line (OD)	1/4" (2)
Suction Line (OD)	3/8" (2)
Refrigerant Precharge	R410a (20 - 50 ft.)
Max Length/Height Diff.	100 Ft. / 50 Ft.

Exterior Unit (Condenser) Specifications

Airflow Rate (cfm)	1,759
Sound Level (dBA)	56.0
Metering Device	Electronic Expansion Valve
Compressor	Twin-Rotary
Dimensions (WDH)	33" x 14-7/8" x 27-1/4"
Weight (Lbs)	96.8

Compatible Indoor Air Handler Units

WT009GLFI22HLD	9,000 BTU (0.75t) 22 SEER 230V (Wall)
WT012GLFI22HLD	12,000 BTU (1t) 22 SEER 230V (Wall)
Quantity	2 (9+9, 12+9, 12+12)
Zone Max Length	65 ft.
Height Difference	100 ft. max between indoor units
Adjustment Charge	0.22 oz/add'l ft. length for <20' or >50'

This combination is Energy-Star® certified when used together with the listed compatible components.



YN020GLFI22M2D Condenser Unit Dimensional Data **PIONEER**

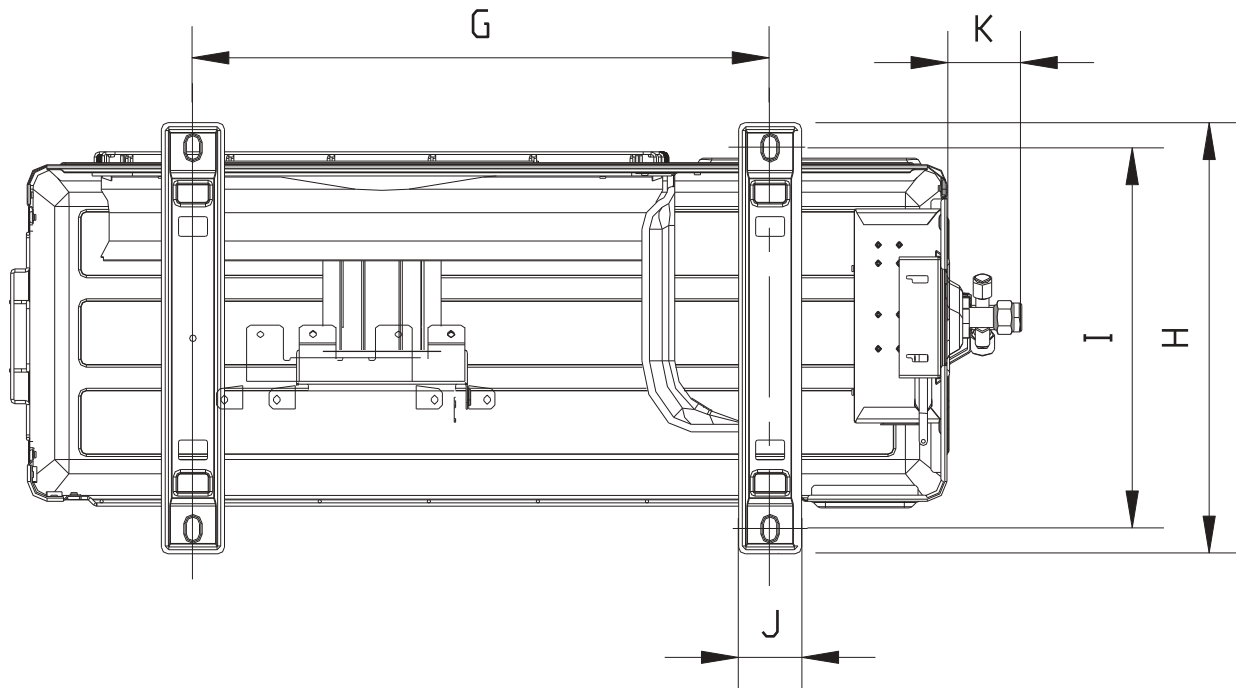

Pioneer WYT Series Mini Split MODEL/Type/Circuit Capacity	D	E	F	G	H	I	J	K
YN020GLFI22M2D (2 Circuit, 1.5 Ton)	845 mm 33-1/4 in.	693 mm 27-1/4 in.	336 mm 13-1/4 in.	586 mm 23-1/16 in.	375 mm 14-3/4 in.	347.5 mm 13-11/16 in.	58.6 mm 2-5/16 in.	63 mm 2-1/2 in.

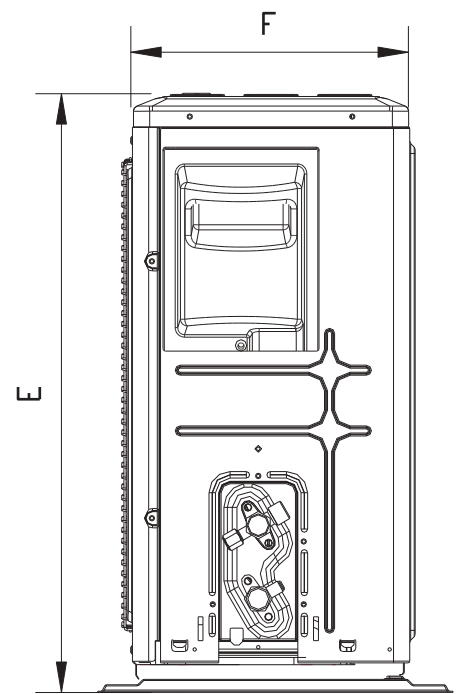
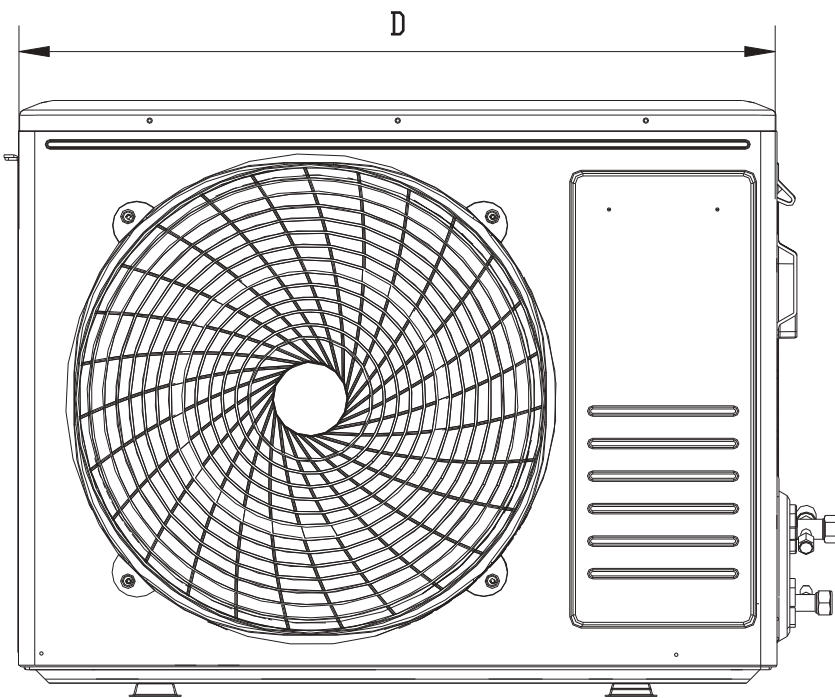

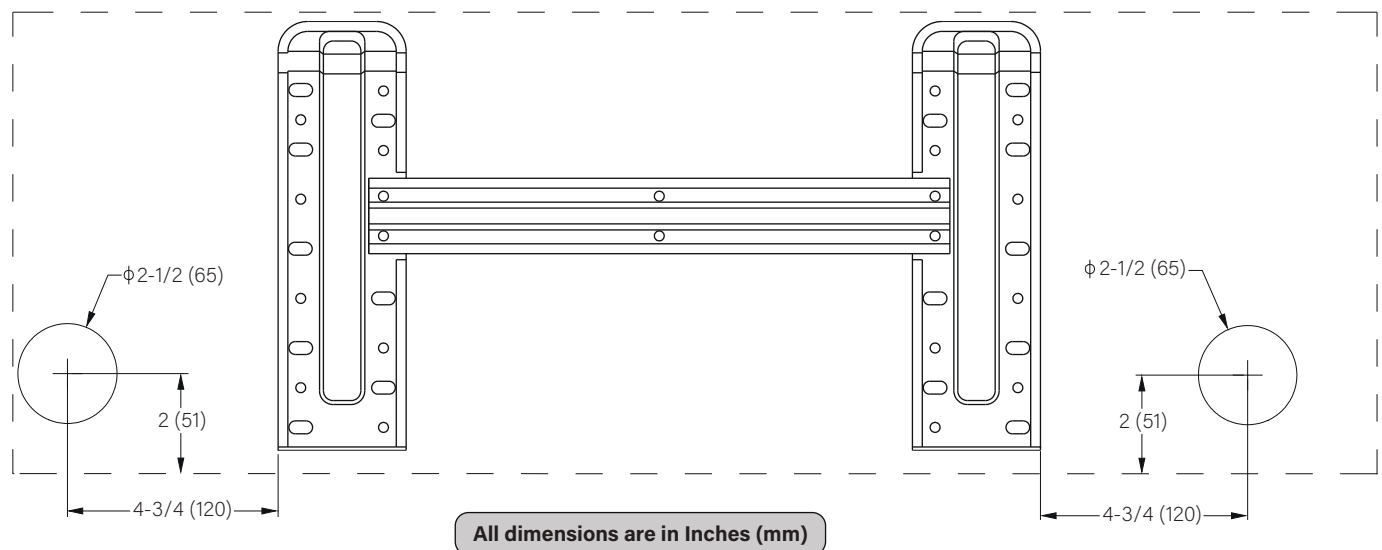
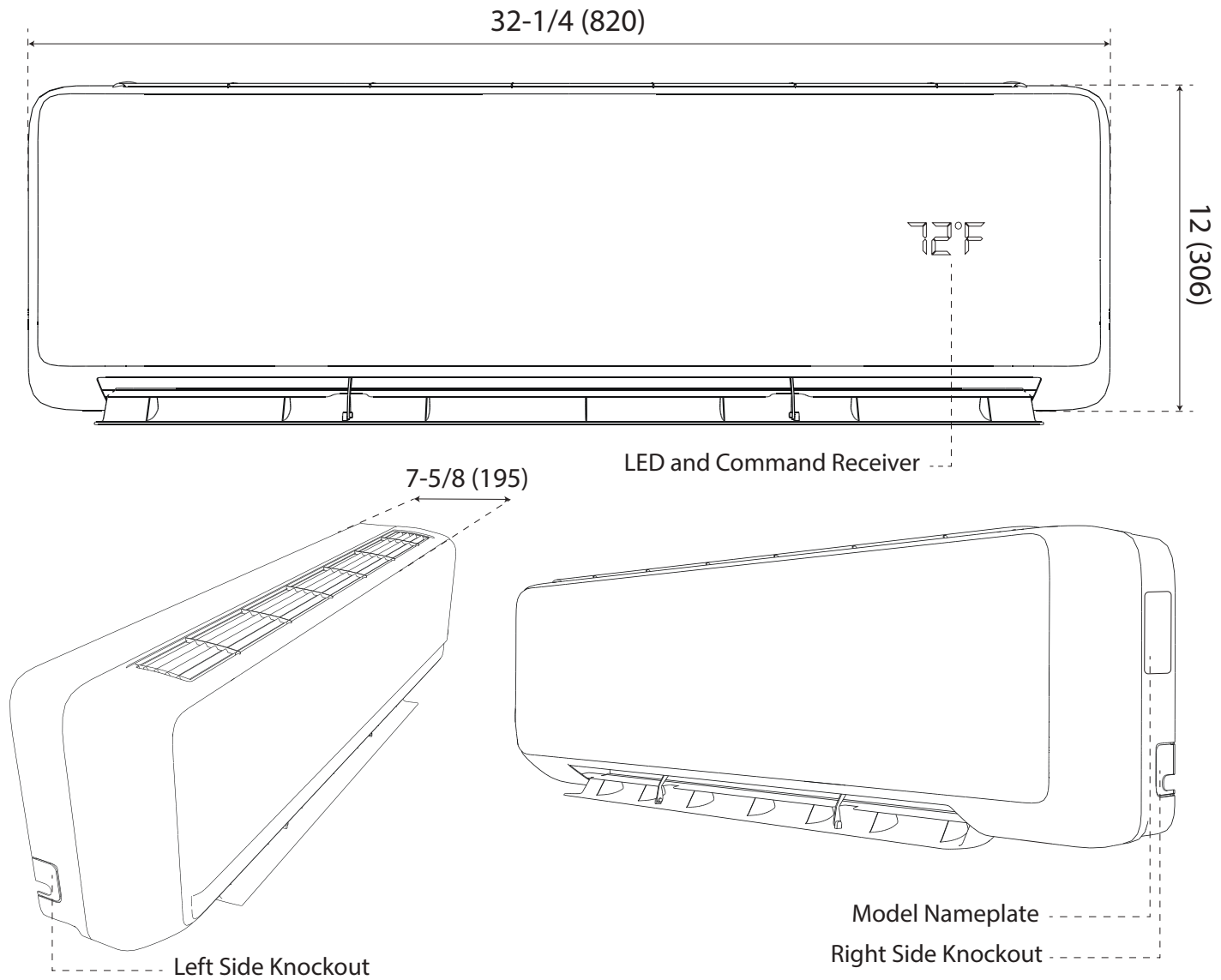

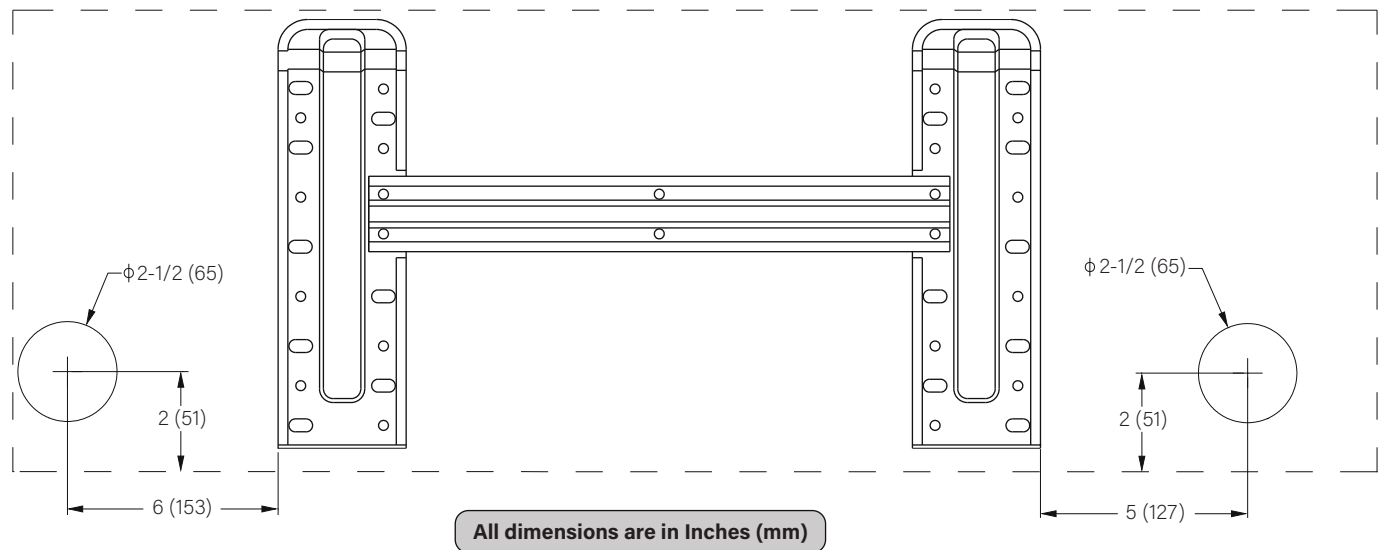
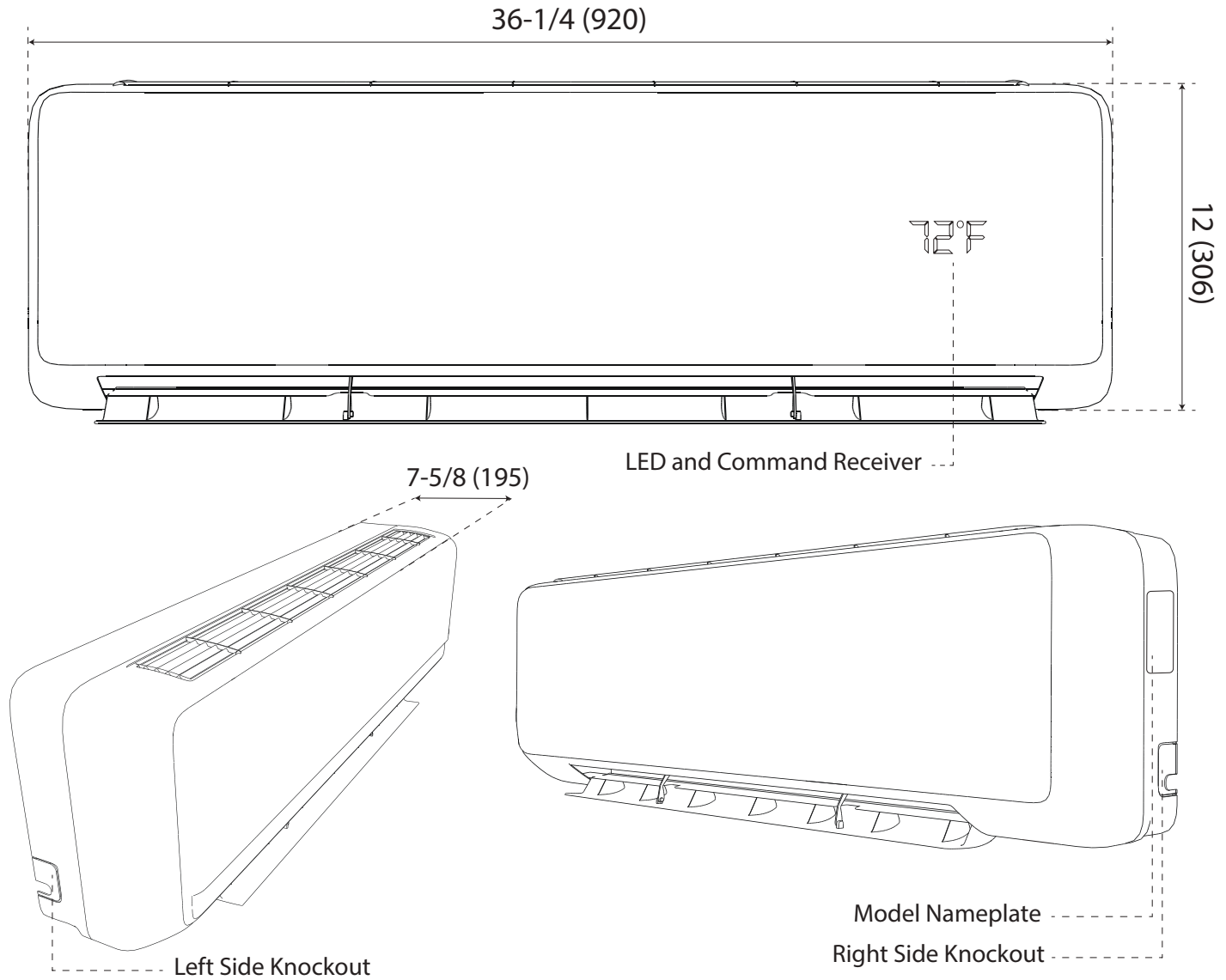

WT009GLFI22HLD (Air Handler) Specifications

Airflow Rate (cfm)	382 (Hi) / 324 (Med) / 265 (Lo)
Sound Level (dBA)	39 (Hi) / 34 (Med) / 29 (Lo) / 27 (Mute)
Auto Air Circulation	2-Way Louver (Up-Down + Left-Right)
Dimensions (WDH)	32"-1/4 x 7"-5/8 x 12"
Weight (Lbs)	19.8

Matching Table (2 Zones Utilized)

9000 + 9000
12000 + 9000
12000 + 12000

WT012GLFI22HLD (Air Handler) Specifications

Airflow Rate (cfm)	471 (Hi) / 382 (Med) / 294 (Lo)
Sound Level (dBA)	39 (Hi) / 34 (Med) / 29 (Lo) / 27 (Mute)
Auto Air Circulation	2-Way Louver (Up-Down + Left-Right)
Dimensions (WDH)	36"-1/4 x 7"-5/8 x 12"
Weight (Lbs)	23.1

Piping Diameters

9000 BTU	1/4" (Liquid) - 3/8" (Suction)
12000 BTU	1/4" (Liquid) - 3/8" (Suction)

Every indoor unit attached to a multi zone system will operate at a random, self regulated capacity, based on the actual demand it measures from the zone it is serving (Between 30% to 100% of its rated capacity) or turn OFF as needed. Although very seldom, if the total demand from the combined group of indoor units' exceeds the rated capacity of the outdoor unit, the capacity of the each indoor unit will be annotated accordingly.

Warranty Information and Length



Complete warranty details are available with the vendor or online at <https://www.pdhvac.com/support/warranty/>. This high quality system is eligible for up to **10** years limited warranty on the compressor, and **7** years on other internal parts. To qualify for this warranty, the system must be installed within 90 days by a registered technician. All other installations that are registered default to **5** years parts/compressor. Products unregistered qualify for only **1** year parts/compressor warranty.

Outstanding Features

- Wi-Fi Enabled
- Auto Restart Function
- ECO Energy Saving Mode
- Vacation Mode (46°F setting)
- DRY Dehumidification Mode
- Dual Directional 3D Air Louver
- 24 hr. Timer & Weekly Scheduling
- I FEEL Remote Thermostat Setting



Available Accessories

Part Number	Description
IKT-LCVR4P-KIT	Decorative PVC Line Cover Kit
CP-RE-MWP-06	Condensate Pump, Multi Voltage
BRK-FRM-C-2P	Folding Mounting Bracket w/ Leveler
IKT-UVL32UL-AG	UVC Bacterial Disinfection Kit
@ICM517	Ultimate Surge and Power Protection