

|               |  |
|---------------|--|
| Job Name:     |  |
| Submitted By: |  |



**Submittal Sheet For:** YN009GLFI22RPD / WT009GLFI22HLD

Date \_\_\_\_\_  
 Ref. \_\_\_\_\_

**Wall Mounted Inverter Driven Heat Pump (0.75 Ton)**

System Full Set Model: **WYT009GLFI22RL**  
 AHRI Reference Number: **207743768**

**Cooling Mode Performance**

|               |              |
|---------------|--------------|
| Rated Cooling | 9000 BTU/hr  |
| Ambient Range | 5°F ~ 122°F  |
| SEER Rating   | 23.0 BTU/W·h |
| EER Rating    | 13.0 BTU/W·h |

\* 100% Capacity @ Indoor DB 80°F/WB 66°F / Outdoor DB 95°F/WB 75°F / m.w. 16" lineset

**Heating Mode Performance**

|               |                    |
|---------------|--------------------|
| Rated Heating | 9500 BTU/hr        |
| Ambient Range | -13°F ~ 86°F       |
| HSPF IV (V)   | 10.0 (8.0) BTU/W·h |
| COP           | 3.5 W/W            |

\* High Heat (47°F) = 9500 BTU / Low Heat (17°F) = 5900 BTU / COP(5°F) = 1.75

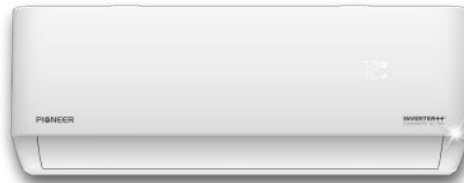

Wall-Mounted Indoor Unit



Outdoor Condensing Unit



16' Installation Kit (Pipe+Cable)



Handheld Remote Controller

**Electrical Information**

| Rated Input (W)   | Cooling             | Heating |
|-------------------|---------------------|---------|
|                   | 710                 | 730     |
| Rated Current (A) | 3.2                 | 3.3     |
| Breaker Needed    | 10A (double-pole)   |         |
| Power Supply      | 208~230V, 1Ph, 60Hz |         |

**Piping and Refrigerant**

|                         |                     |
|-------------------------|---------------------|
| Liquid Line (OD)        | 1/4"                |
| Suction Line (OD)       | 3/8"                |
| Refrigerant Precharge   | R410a (10 - 25 ft.) |
| Max Length/Height Diff. | 50 Ft. / 33 Ft.     |

This combination is Energy-Star® certified.



**Interior Unit (Air Handler) Specifications**

|                      |  |
|----------------------|--|
| Airflow Rate (cfm)   | 382 (Hi) / 324 (Med) / 265 (Lo)          |
| Sound Level (dBA)    | 39 (Hi) / 34 (Med) / 29 (Lo) / 27 (Mute) |
| Auto Air Circulation | 2-Way Louver (Up-Down + Left-Right)      |
| Dimensions (WDH)     | 32"-1/4 x 7"-5/8 x 12"                   |
| Weight (Lbs)         | 19.8                                     |

**Exterior Unit (Condenser) Specifications**

|                    |                         |
|--------------------|-------------------------|
| Airflow Rate (cfm) | 1,235                   |
| Sound Level (dBA)  | 50.0                    |
| Metering Device    | Capillary Tube          |
| Compressor         | Rotary                  |
| Dimensions (WDH)   | 28"-5/8 x 12" x 21-5/8" |
| Weight (Lbs)       | 51.4                    |

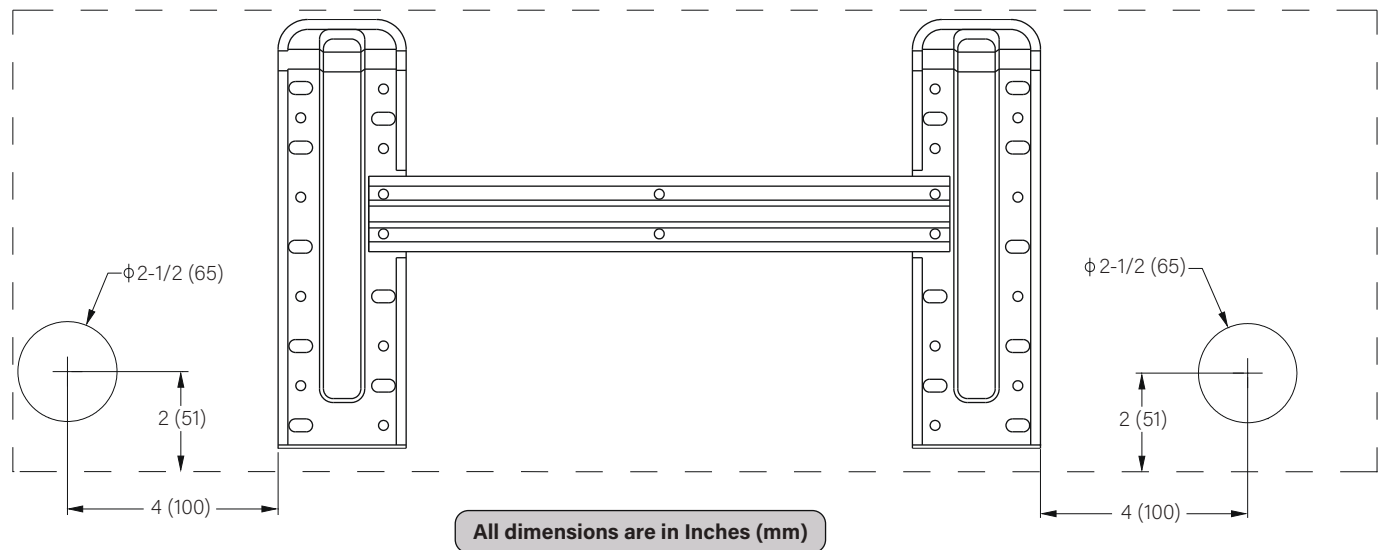
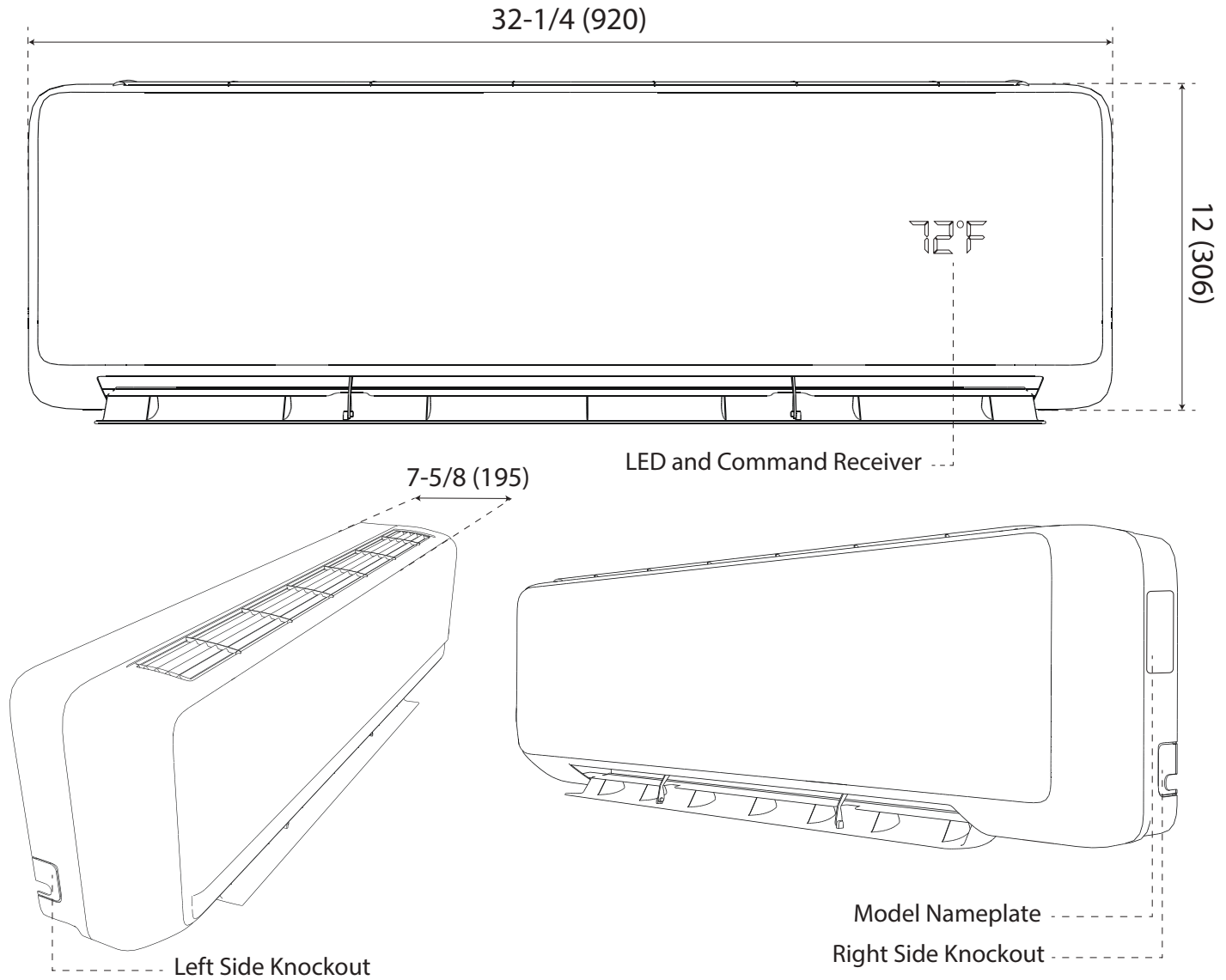

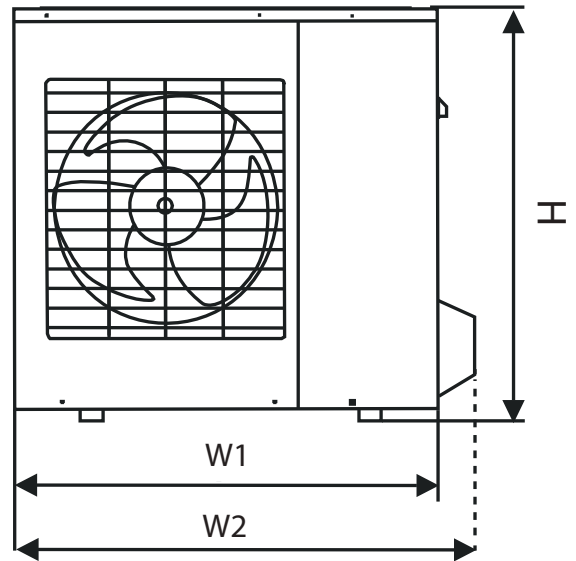
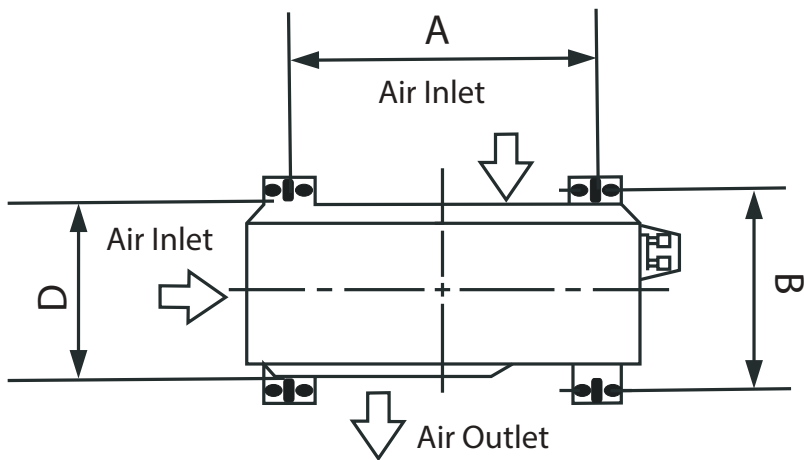

| Pioneer WYT Series Mini Split<br>MODEL/Capacity (Btu/h) | A                    | B                      | D                | H                    | W1                   | W2                   |
|---|----------------------|------------------------|------------------|----------------------|----------------------|----------------------|
| YN009GLFI22RPD (9,000 BTU - 208/230V)                   | 438 mm<br>17-1/4 in. | 278 mm<br>10-15/16 in. | 255 mm<br>10 in. | 546 mm<br>21-1/2 in. | 728 mm<br>28-5/8 in. | 810 mm<br>31-7/8 in. |

### Warranty Information and Length



Complete warranty details are available with the vendor or online at <https://www.pdhvac.com/support/warranty/>. This high quality system is eligible for up to **10** years limited warranty on the compressor, and **7** years on other internal parts. To qualify for this warranty, the system must be installed within 90 days by a registered technician. All other installations that are registered default to **5** years parts/compressor. Products unregistered qualify for only **1** year parts/compressor warranty.

### Outstanding Features

- Wi-Fi Enabled
- Auto Restart Function
- ECO Energy Saving Mode
- Vacation Mode (46°F setting)
- DRY Dehumidification Mode
- Dual Directional 3D Air Louver
- 24 hr. Timer & Weekly Scheduling
- I FEEL Remote Thermostat Setting



### Available Accessories

| Part Number    | Description                                |
|----------------|--|
| IKT-LCVR4P-KIT | <i>Decorative PVC Line Cover Kit</i>       |
| CP-RE-MWP-06   | <i>Condensate Pump, Multi Voltage</i>      |
| BRK-FRM-C-2P   | <i>Folding Mounting Bracket w/ Leveler</i> |
| IKT-UVL32UL-AG | <i>UVC Bacterial Disinfection Kit</i>      |
| @ICM517        | <i>Ultimate Surge and Power Protection</i> |