

Job Name:	
Submitted By:	



**Submittal Sheet For:** YN012GLFI22RPD / WT012GLFI22HLD

Date \_\_\_\_\_  
 Ref. \_\_\_\_\_

**Wall Mounted Inverter Driven Heat Pump (1 Ton)**

System Full Set Model: **WYT012GLFI22RL**  
 AHRI Reference Number: **207743769**

**Cooling Mode Performance**

Rated Cooling	12000 BTU/hr
Ambient Range	5°F ~ 122°F
SEER Rating	23.0 BTU/W·h
EER Rating	13.0 BTU/W·h

\* 100% Capacity @ Indoor DB 80°F/WB 66°F / Outdoor DB 95°F/WB 75°F / m.w. 16" lineset

**Heating Mode Performance**

Rated Heating	12000 BTU/hr
Ambient Range	-13°F ~ 86°F
HSPF IV (V)	10.0 (8.0) BTU/W·h
COP	3.5 W/W

\* High Heat (47°F) = 12000 BTU / Low Heat (17°F) = 7600 BTU / COP(5°F) = 1.75

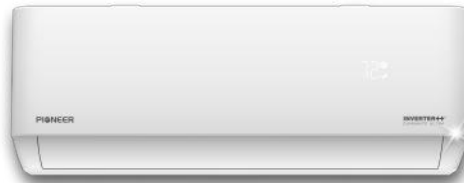

Wall-Mounted Indoor Unit



Outdoor Condensing Unit



16' Installation Kit (Pipe+Cable)



Handheld Remote Controller

**Electrical Information**

Rated Input (W)	Cooling	Heating
	920	910
Rated Current (A)	4.1	4.1
Breaker Needed	15A (double-pole)	
Power Supply	208~230V, 1Ph, 60Hz	

**Piping and Refrigerant**

Liquid Line (OD)	1/4"
Suction Line (OD)	3/8"
Refrigerant Precharge	R410a (10 - 25 ft.)
Max Length/Height Diff.	50 Ft. / 33 Ft.

This combination is Energy-Star® certified.



**Interior Unit (Air Handler) Specifications**

Airflow Rate (cfm)	471 (Hi) / 382 (Med) / 294 (Lo)
Sound Level (dBA)	39 (Hi) / 34 (Med) / 29 (Lo) / 27 (Mute)
Auto Air Circulation	2-Way Louver (Up-Down + Left-Right)
Dimensions (WDH)	36"-1/4 x 7"-5/8 x 12"
Weight (Lbs)	23.1

**Exterior Unit (Condenser) Specifications**

Airflow Rate (cfm)	1,235
Sound Level (dBA)	52.0
Metering Device	Capillary Tube
Compressor	Rotary
Dimensions (WDH)	28"-5/8 x 12" x 21-5/8"
Weight (Lbs)	59.1

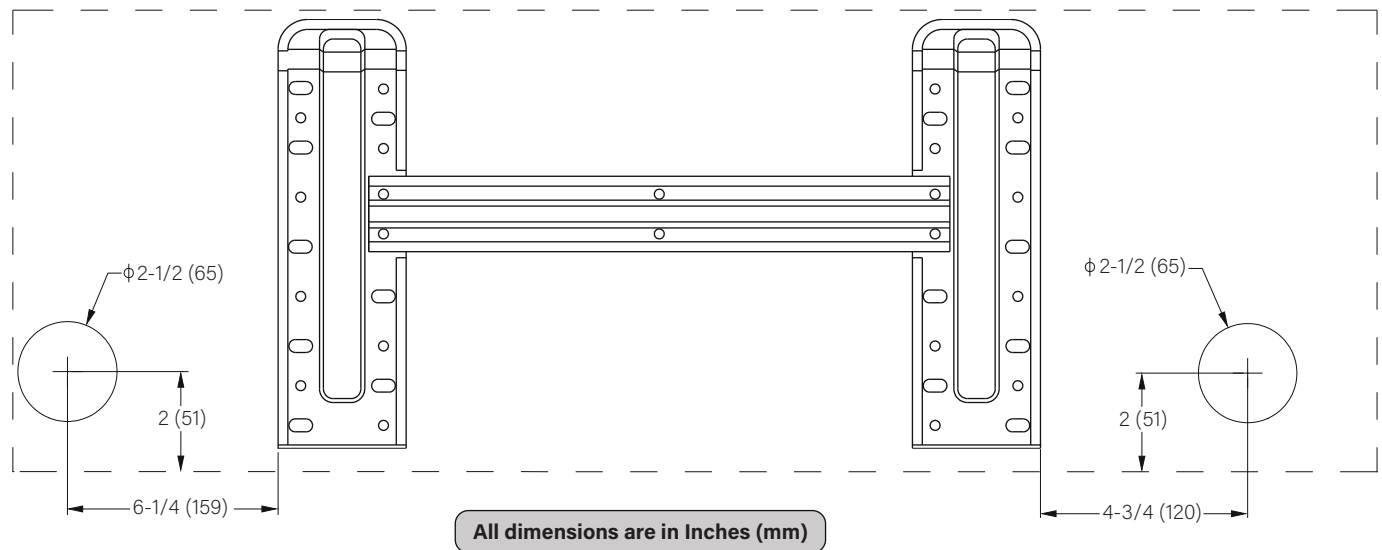
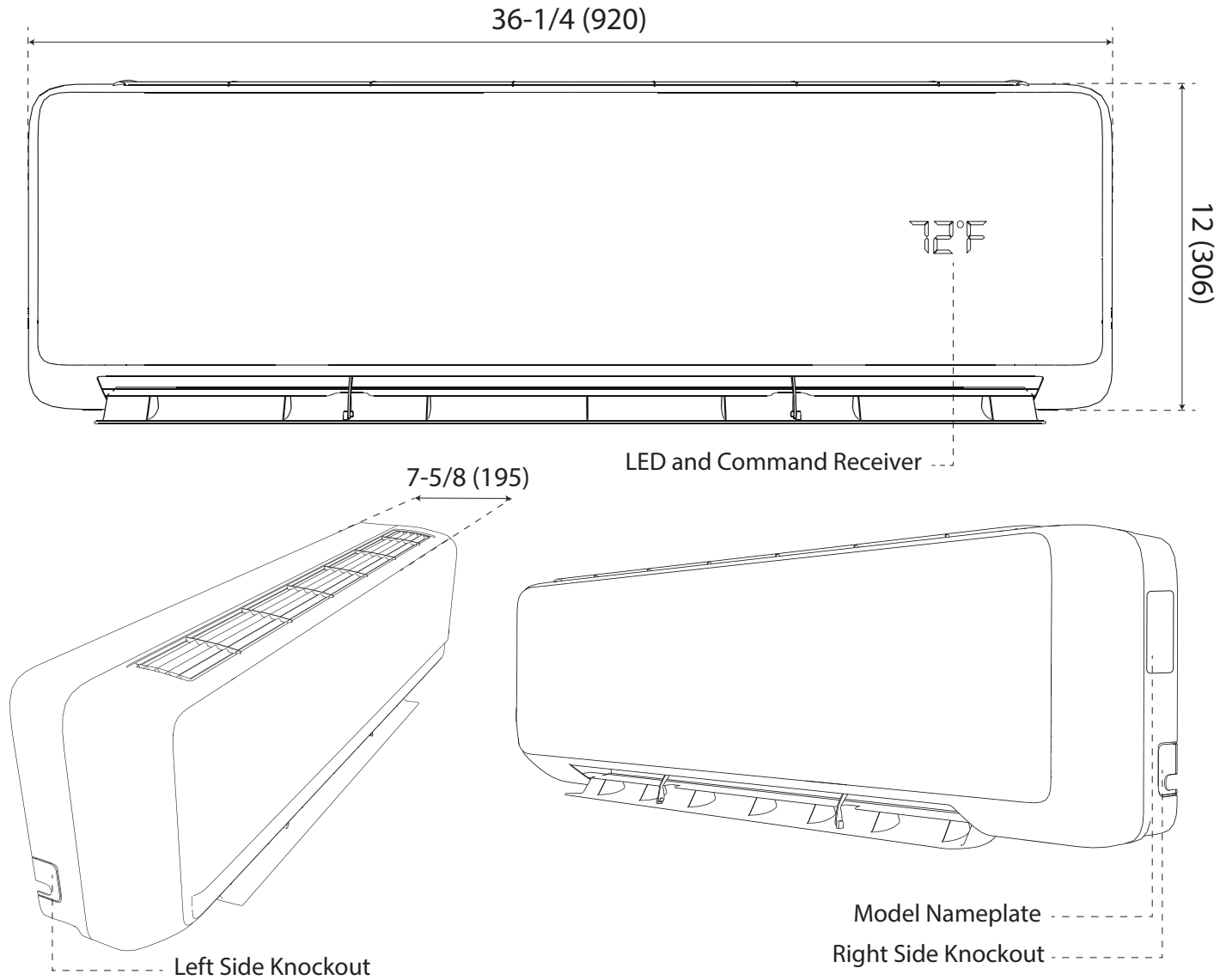

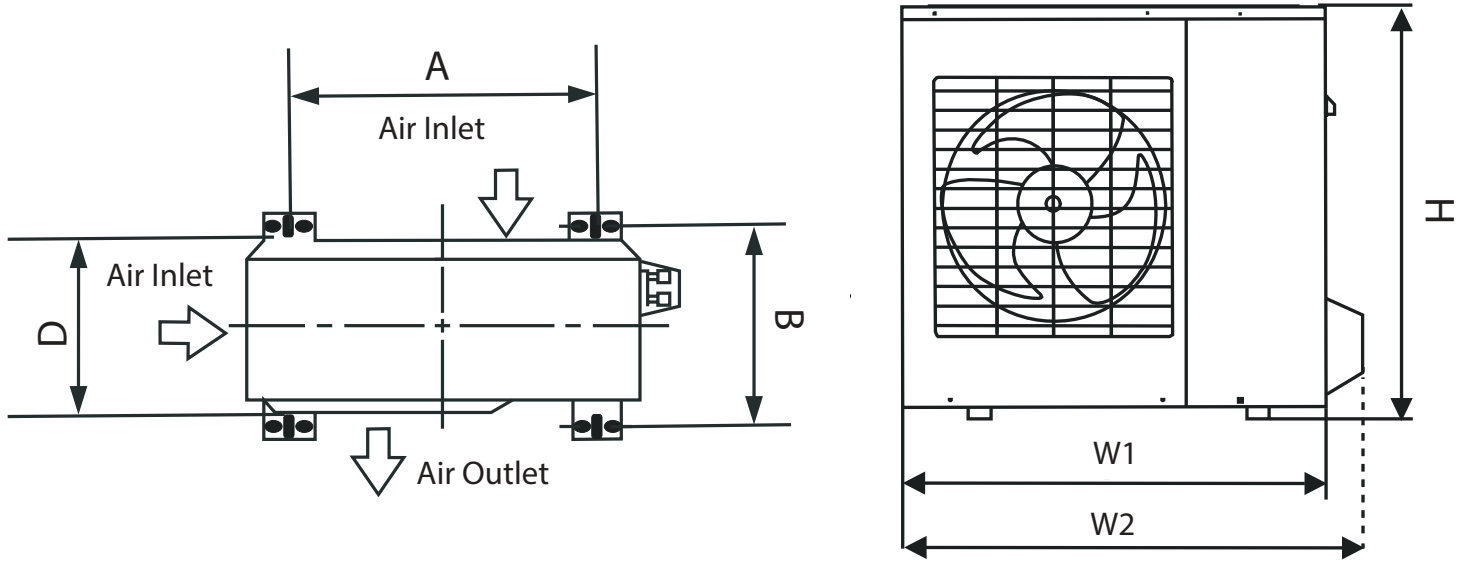

Pioneer WYT Series Mini Split MODEL/Capacity (Btu/h)	A	B	D	H	W1	W2
YN012GLFI22RPD (12,000 BTU - 208/230V)	438 mm 17-1/4 in.	278 mm 10-15/16 in.	255 mm 10 in.	546 mm 21-1/2 in.	728 mm 28-5/8 in.	810 mm 31-7/8 in.

### Warranty Information and Length



Complete warranty details are available with the vendor or online at <https://www.pdhvac.com/support/warranty/>. This high quality system is eligible for up to **10** years limited warranty on the compressor, and **7** years on other internal parts. To qualify for this warranty, the system must be installed within 90 days by a registered technician. All other installations that are registered default to **5** years parts/compressor. Products unregistered qualify for only **1** year parts/compressor warranty.

### Outstanding Features

- Wi-Fi Enabled
- Auto Restart Function
- ECO Energy Saving Mode
- Vacation Mode (46°F setting)
- DRY Dehumidification Mode
- Dual Directional 3D Air Louver
- 24 hr. Timer & Weekly Scheduling
- I FEEL Remote Thermostat Setting



### Available Accessories

Part Number	Description
IKT-LCVR4P-KIT	<i>Decorative PVC Line Cover Kit</i>
CP-RE-MWP-06	<i>Condensate Pump, Multi Voltage</i>
BRK-FRM-C-2P	<i>Folding Mounting Bracket w/ Leveler</i>
IKT-UVL32UL-AG	<i>UVC Bacterial Disinfection Kit</i>
@ICM517	<i>Ultimate Surge and Power Protection</i>