

Job Name:	
Submitted By:	



Submittal Sheet For: YN024GLFI22RPD / WT024GLFI22HLD

Date _____
 Ref. _____

Wall Mounted Inverter Driven Heat Pump (2 Ton)

System Full Set Model: **WYT024GLFI22RL**
 AHRI Reference Number: **207743771**

Cooling Mode Performance

Rated Cooling	23000 BTU/hr
Ambient Range	5°F ~ 122°F
SEER Rating	20.0 BTU/W·h
EER Rating	12.5 BTU/W·h

* 100% Capacity @ Indoor DB 80°F/WB 66°F / Outdoor DB 95°F/WB 75°F / m.w. 16"lineset

Heating Mode Performance

Rated Heating	24000 BTU/hr
Ambient Range	-13°F ~ 86°F
HSPF IV (V)	10.0 (8.0) BTU/W·h
COP	3.0 W/W

* High Heat (47°F) = 24000 BTU / Low Heat (17°F) = 13900 BTU / COP(5°F) = 1.75

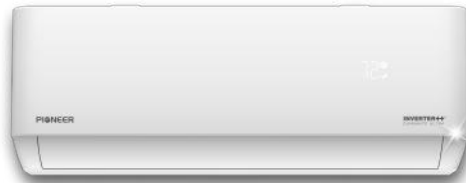

Wall-Mounted Indoor Unit



Outdoor Condensing Unit



16' Installation Kit (Pipe+Cable)



Handheld Remote Controller

Electrical Information

Rated Input (W)	Cooling	Heating
	1,920	2,050
Rated Current (A)	8.6	9.2
Breaker Needed	20A (double-pole)	
Power Supply	208~230V, 1Ph, 60Hz	

Piping and Refrigerant

Liquid Line (OD)	1/4"
Suction Line (OD)	5/8"
Refrigerant Precharge	R410a (10 - 25 ft.)
Max Length/Height Diff.	50 Ft. / 33 Ft.

This combination is Energy-Star® certified.



Interior Unit (Air Handler) Specifications

Airflow Rate (cfm)	735 (Hi) / 618 (Med) / 529 (Lo)
Sound Level (dBA)	45 (Hi) / 40 (Med) / 35 (Lo) / 31 (Mute)
Auto Air Circulation	2-Way Louver (Up-Down + Left-Right)
Dimensions (WDH)	43"-3/8 x 8"-3/4 x 13"-1/8
Weight (Lbs)	30.9

Exterior Unit (Condenser) Specifications

Airflow Rate (cfm)	2,645
Sound Level (dBA)	58.0
Metering Device	Capillary Tube
Compressor	Rotary
Dimensions (WDH)	35"-7/8 x 15"-5/8 x 31"-5/8"
Weight (Lbs)	104.7

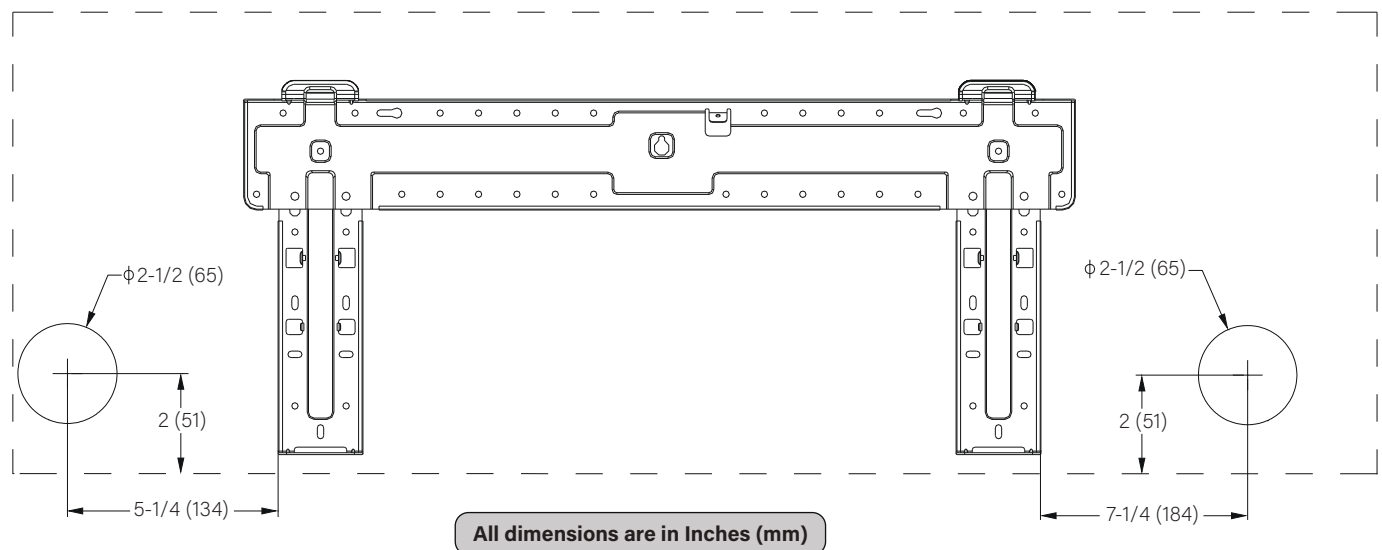
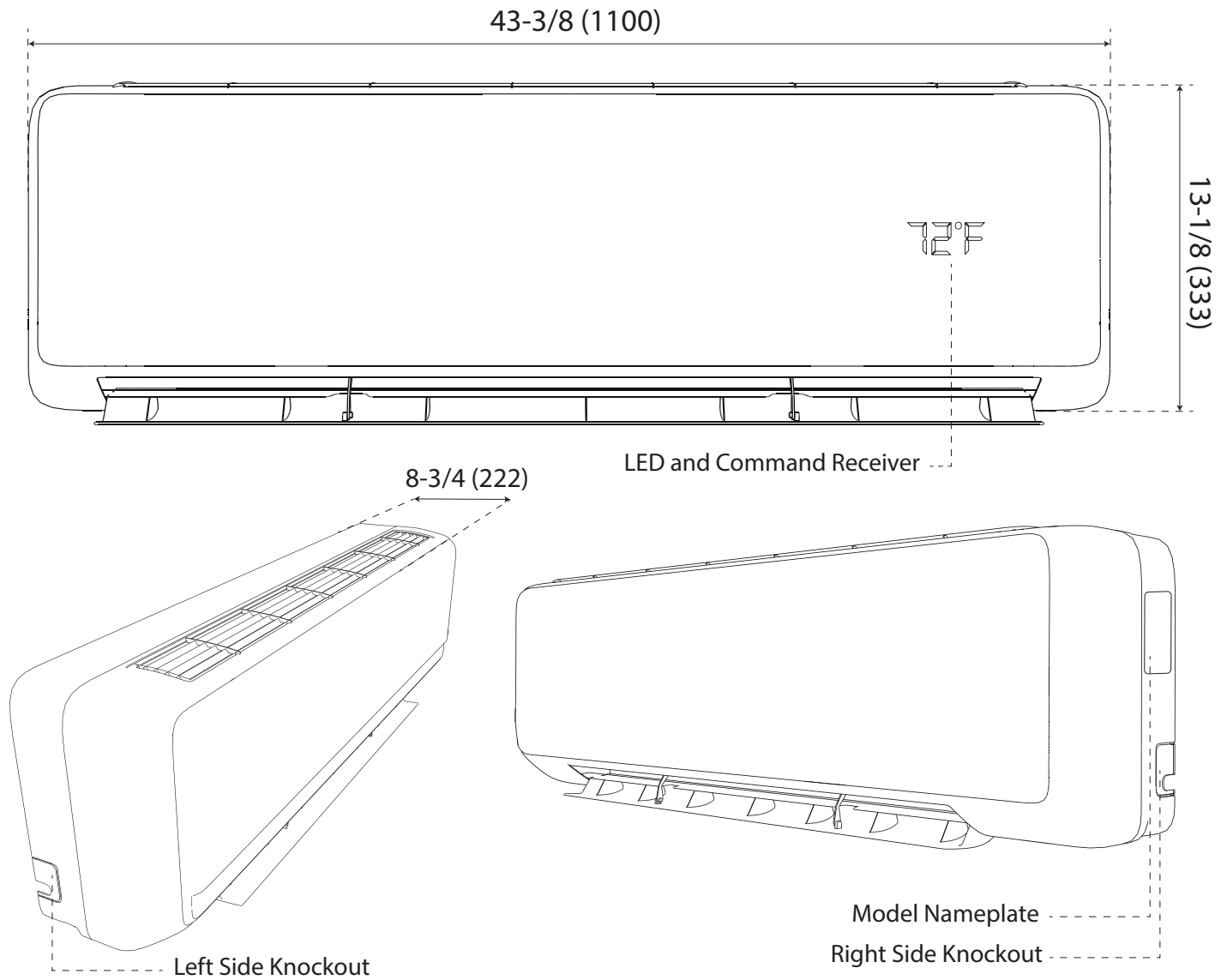

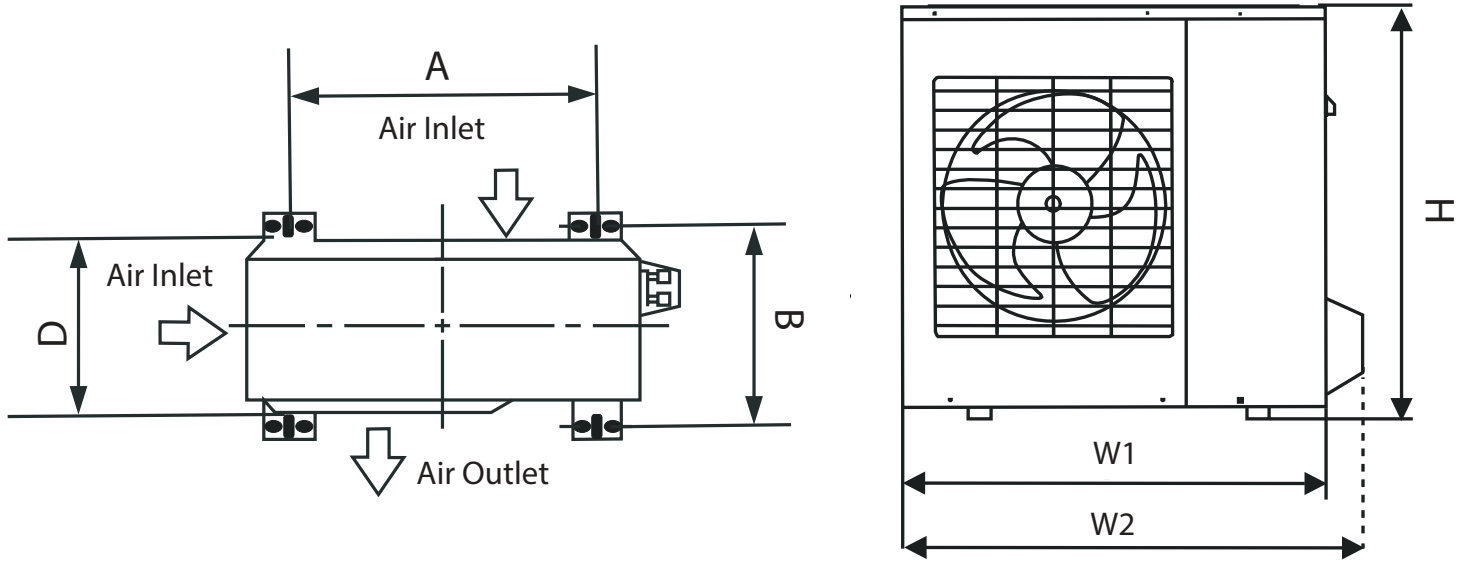

Pioneer WYT Series Mini Split MODEL/Capacity (Btu/h)	A	B	D	H	W1	W2
YN024GLFI22RPD (24,000 BTU - 208/230V)	607 mm 23-7/8 in.	390 mm 15-3/8 in.	397 mm 15-5/8 in.	804 mm 31-5/8 in.	910 mm 35-7/8 in.	978 mm 38-1/2 in.

Warranty Information and Length



Complete warranty details are available with the vendor or online at <https://www.pdhvac.com/support/warranty/>. This high quality system is eligible for up to **10** years limited warranty on the compressor, and **7** years on other internal parts. To qualify for this warranty, the system must be installed within 90 days by a registered technician. All other installations that are registered default to **5** years parts/compressor. Products unregistered qualify for only **1** year parts/compressor warranty.

Outstanding Features

- Wi-Fi Enabled
- Auto Restart Function
- ECO Energy Saving Mode
- Vacation Mode (46°F setting)
- DRY Dehumidification Mode
- Dual Directional 3D Air Louver
- 24 hr. Timer & Weekly Scheduling
- I FEEL Remote Thermostat Setting



Available Accessories

Part Number	Description
IKT-LCVR4P-KIT	<i>Decorative PVC Line Cover Kit</i>
CP-RE-MWP-06	<i>Condensate Pump, Multi Voltage</i>
BRK-FRM-C-2P	<i>Folding Mounting Bracket w/ Leveler</i>
IKT-UVL32UL-AG	<i>UVC Bacterial Disinfection Kit</i>
@ICM517	<i>Ultimate Surge and Power Protection</i>